

Universal Stands



Manufacturer's Information

Copyright

© Copyright 09/2023 by Alto-Shaam, Inc.

All rights reserved.

This manual or any portion thereof may not be reproduced or used in any manner whatsoever without the express written permission of Alto-Shaam, Inc.

Trademarks

All trademarks referenced in this documentation are the property of their respective owners.

Manufacturer

Alto-Shaam, Inc.

P.O. Box 450

W164 N9221 Water Street

Menomonee Falls, WI 53052

Original instructions

The content in this manual is written in American English.

The information in this Guide was current at the time of publication. Scan or click the QR code below for the latest version.



Contents

Top Units	4
Bottom Units.....	5
Combinations—21-1/2" (546mm) Wide Stands	10
Combinations—23" (584mm) Wide Stands.....	12
Combinations—25-1/2" (648mm) Wide Stands	20
Combinations—29-1/2" (749mm) Wide Stands.....	29
Stand Details.....	40

How To Use This Guide

The stands in this guide are designed to accommodate various combinations of Alto-Shaam equipment. Follow the steps below to choose a compatible stand for your application.

1. Select the desired top unit from the options shown on page 4. Each top unit is assigned a letter.
2. Select the bottom unit (if desired) from the options shown on pages 5–9. Each bottom unit is assigned a number.
3. Beginning on page 10, identify compatible stands by matching letter/number combinations with those of your desired equipment. Stands are organized in ascending order by width.



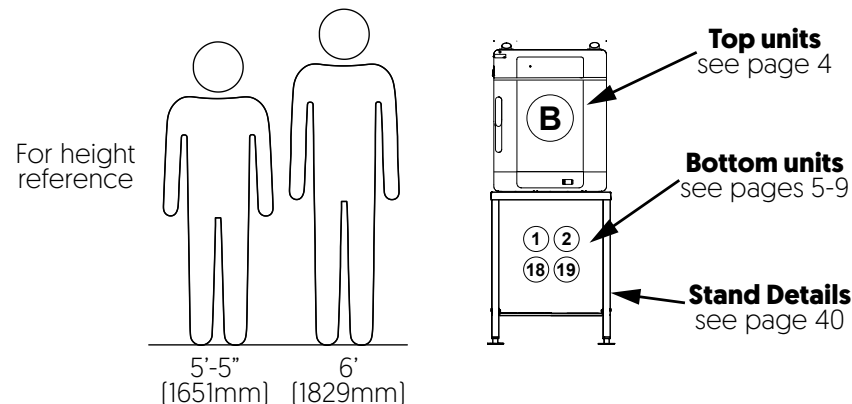

Note: A slash symbol (Ø) indicates a stand cannot accommodate a bottom unit.

Stands can be shipped either preassembled or unassembled (flat-packed). Part numbers in this Guide represent preassembled stands. To order an unassembled version, add an "R" to the part number when ordering.

Human figures are provided next to each combination to give a sense of the overall height of the oven on the stand. Detailed dimensional views of each stand can be found on pages 42-51.







Top Units

Letter	Image	Model	Description
A		CTX4-10E	CT Express™ Combitherm® Ovens
B		CMC-H2H CMC-H3H	Converge® Multi-Cook Ovens
C		VMC-H2/H2H VMC-H3/H3H VMC-H4/H4H	Vector® H Series Multi-Cook Ovens
D		VMC-H2HW VMC-H3HW	Vector® H Series Multi-Cook Ovens, Wide
E		750-SK 750-TH	Cook & Hold Smoker Oven Cook & Hold Oven





Bottom Units

Note: Bottom units placed on lower shelves must be equipped with legs; not casters.

Number	Image	Model	Description
1		300-S	Low-Temperature Holding Cabinet
2		300-TH	Cook & Hold Oven
3		500-S	Low-Temperature Holding Cabinet
4		500-S [except ovens with 5" [127mm] casters]	Low-Temperature Holding Cabinet
5		500-TH	Cook & Hold Oven





Bottom Units [continued]

Note: Bottom units placed on lower shelves must be equipped with legs; not casters.







Number	Image	Model	Description
6		750-TH	Cook & Hold Oven
7		750-S	Low-Temperature Holding Cabinet
8		750-S [except ovens with 5" [127mm] casters]	Low-Temperature Holding Cabinet
9		1000-S	Low-Temperature Holding Cabinet
10		1000-S [except ovens with 5" [127mm] casters]	Low-Temperature Holding Cabinet

Bottom Units [continued]

Note: Bottom units placed on lower shelves must be equipped with legs; not casters.





Number	Image	Model	Description
11		1000-TH	Cook & Hold Oven
12		1200-S	Low-Temperature Holding Cabinet
13		500-1D	Drawer Warmer
14		500-2D	Drawer Warmer
15		500-2D [3" [76mm] casters only]	Drawer Warmer

Bottom Units [continued]**Note:** Bottom units placed on lower shelves must be equipped with legs; not casters.

Number	Image	Model	Description
16		500-3D	Drawer Warmer
17		500-2DI	Drawer Warmer
18		500-1DN	Drawer Warmer, Narrow
19		500-2DN	Drawer Warmer, Narrow
20		500-2DN [3" (76mm) casters only]	Drawer Warmer, Narrow
21		500-3DN	Drawer Warmer, Narrow

Bottom Units [continued]

Note: Bottom units placed on lower shelves must be equipped with legs; not casters.

Number	Image	Model	Description
22		VMC-H2/H2H	Vector Multi-Cook Oven, 2 Chamber
23		VMC-H3/H3H	Vector Multi-Cook Oven, 3 Chamber
24		VMC-H4/H4H	Vector Multi-Cook Oven, 4 Chamber
25		VMC-H2HW	Vector H Series Multi-Cook Oven, 2 Chamber, Wide
26		VMC-H3HW	Vector H Series Multi-Cook Oven, 3 Chamber, Wide

Combinations—21-1/2" (546mm) Wide Stands

Note: The human figures at left are provided for general height reference. They are depicted as 5'-5" [1651mm] and 6' [1829mm] tall.

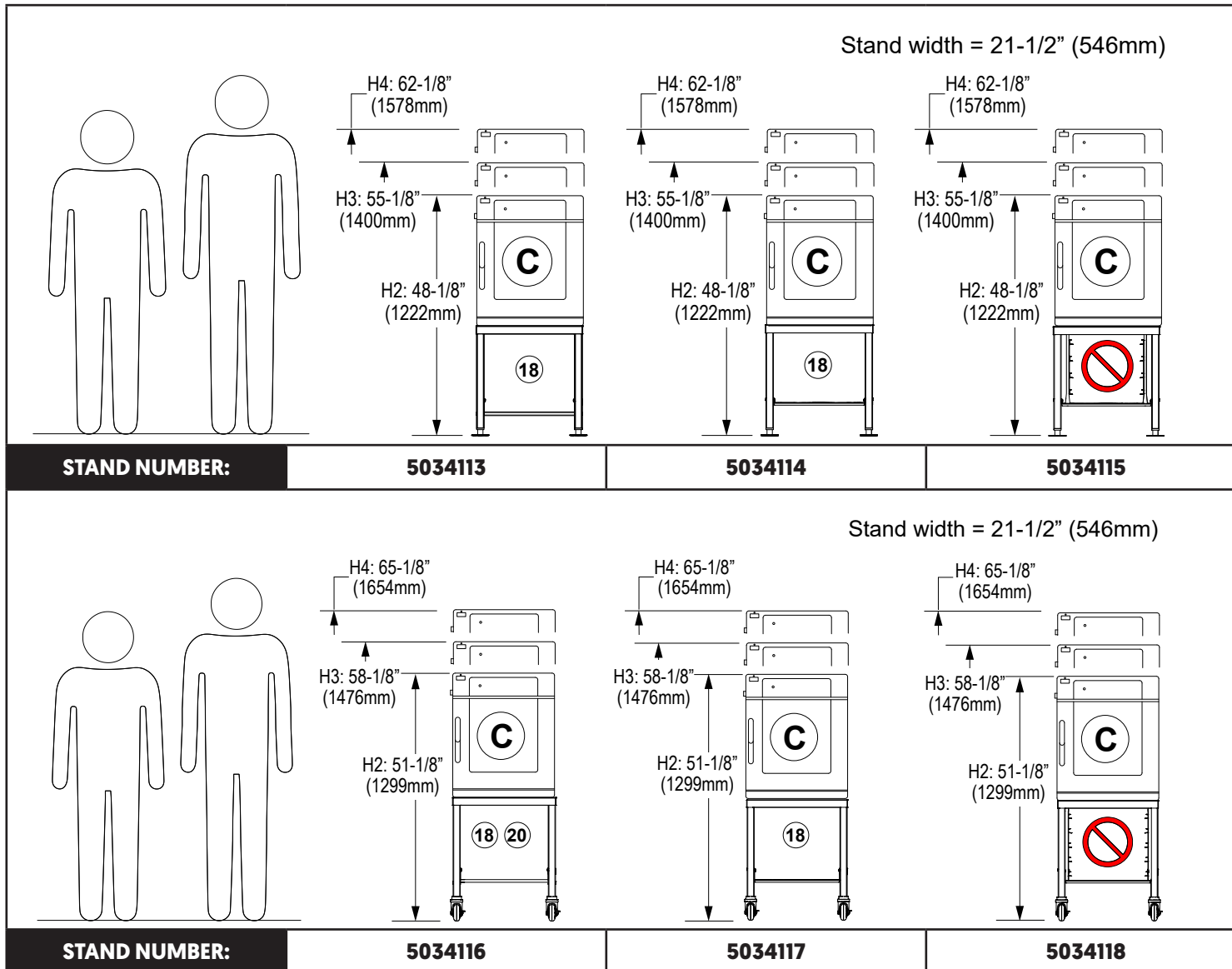

Combinations—21-1/2" (546mm) Wide Stands [continued]

Note: The human figures at left are provided for general height reference. They are depicted as 5'-5" [1651mm] and 6' [1829mm] tall.

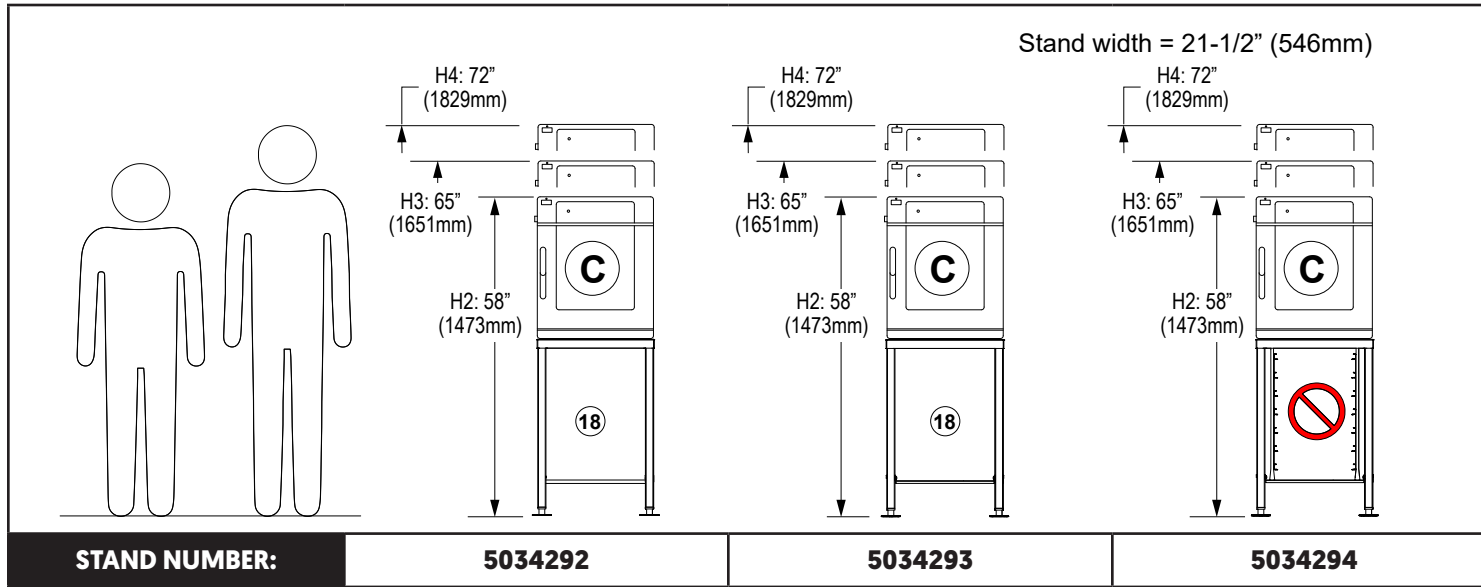

Combinations—23" (584mm) Wide Stands

Note: The human figures at left are provided for general height reference. They are depicted as 5'-5" (1651mm) and 6' (1829mm) tall.

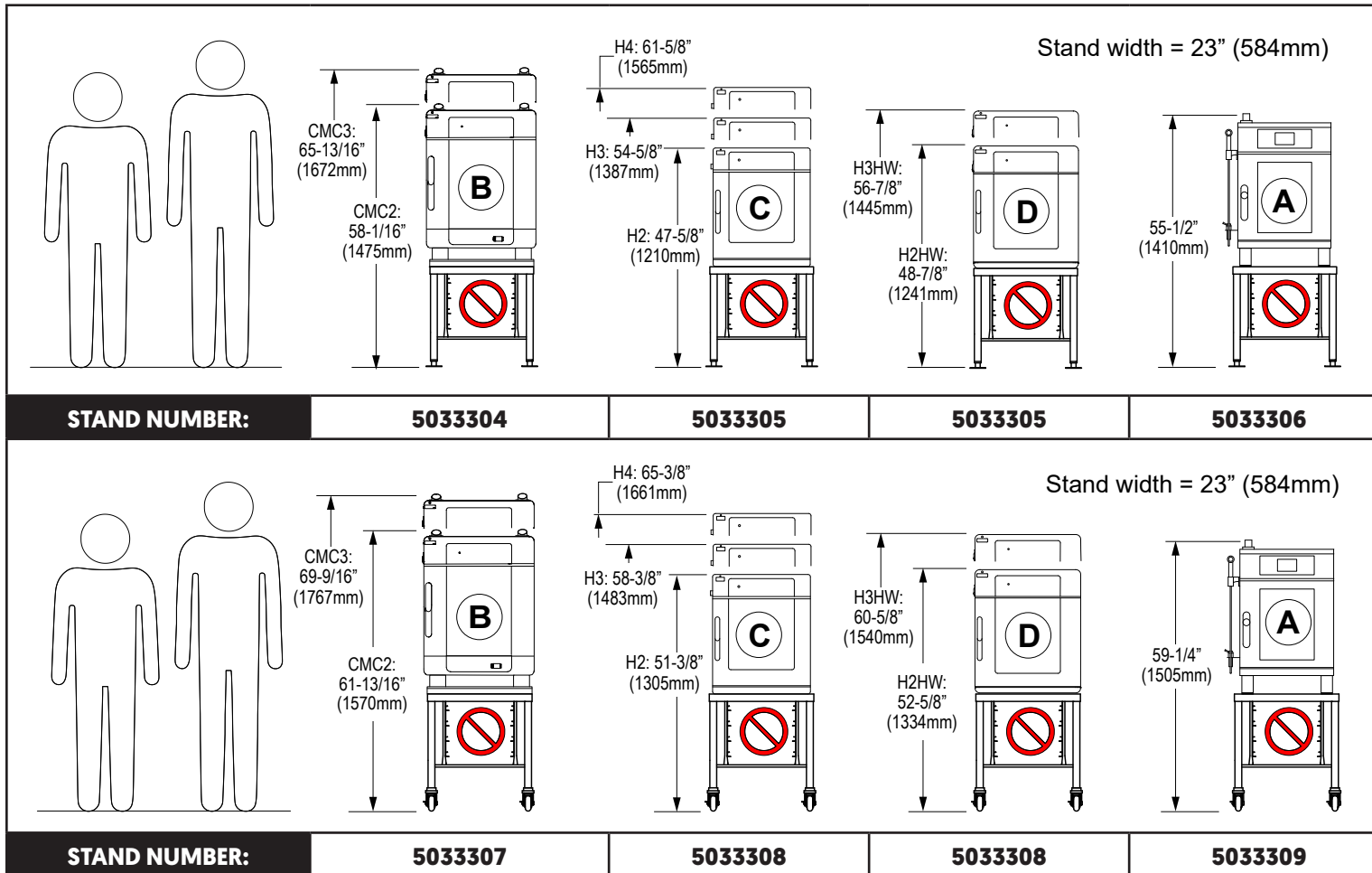

Combinations—23" (584mm) Wide Stands [continued]

Note: The human figures at left are provided for general height reference. They are depicted as 5'-5" (1651mm) and 6' (1829mm) tall.

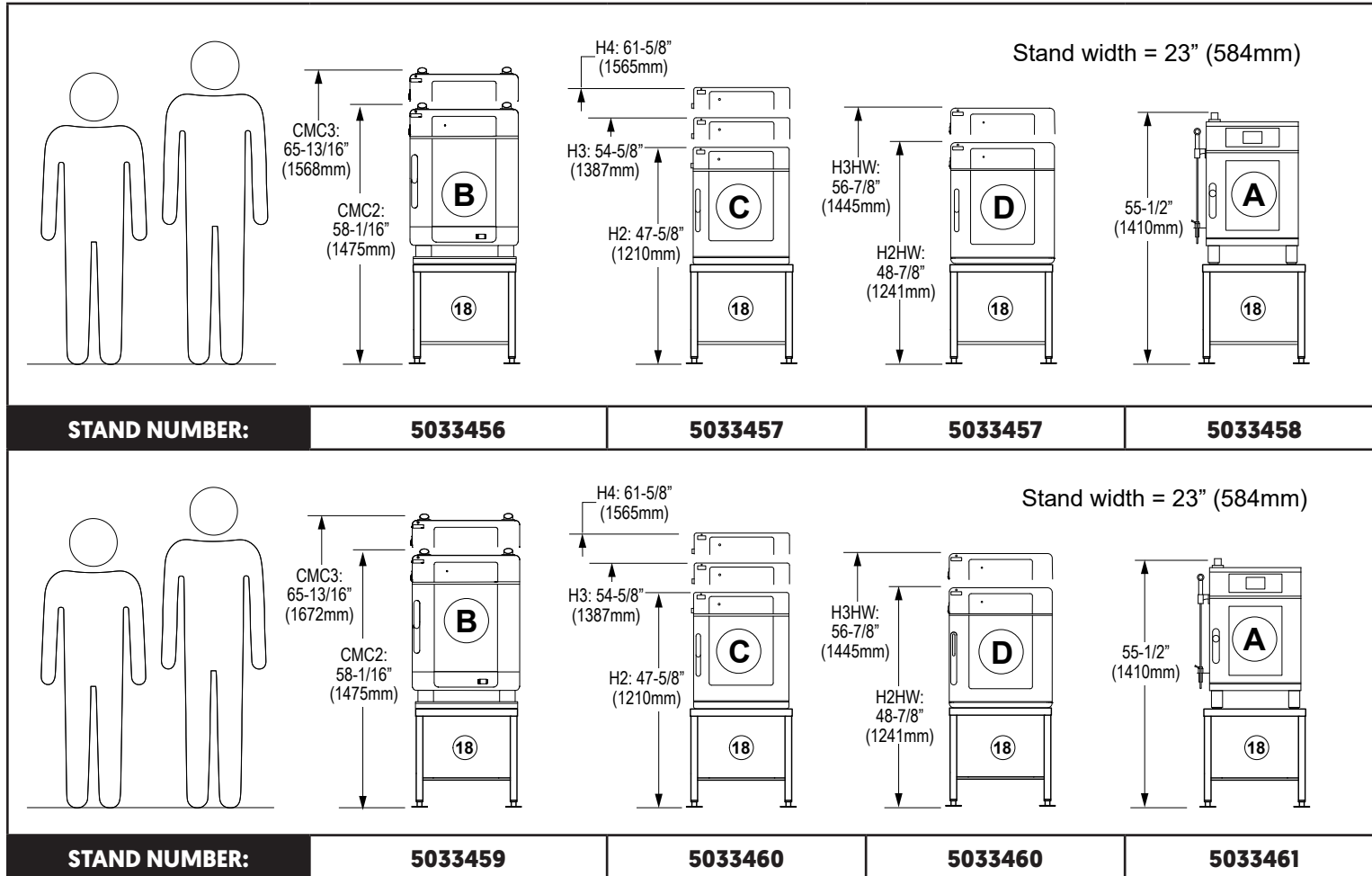

Combinations—23" (584mm) Wide Stands [continued]

Note: The human figures at left are provided for general height reference. They are depicted as 5'-5" (1651mm) and 6' (1829mm) tall.

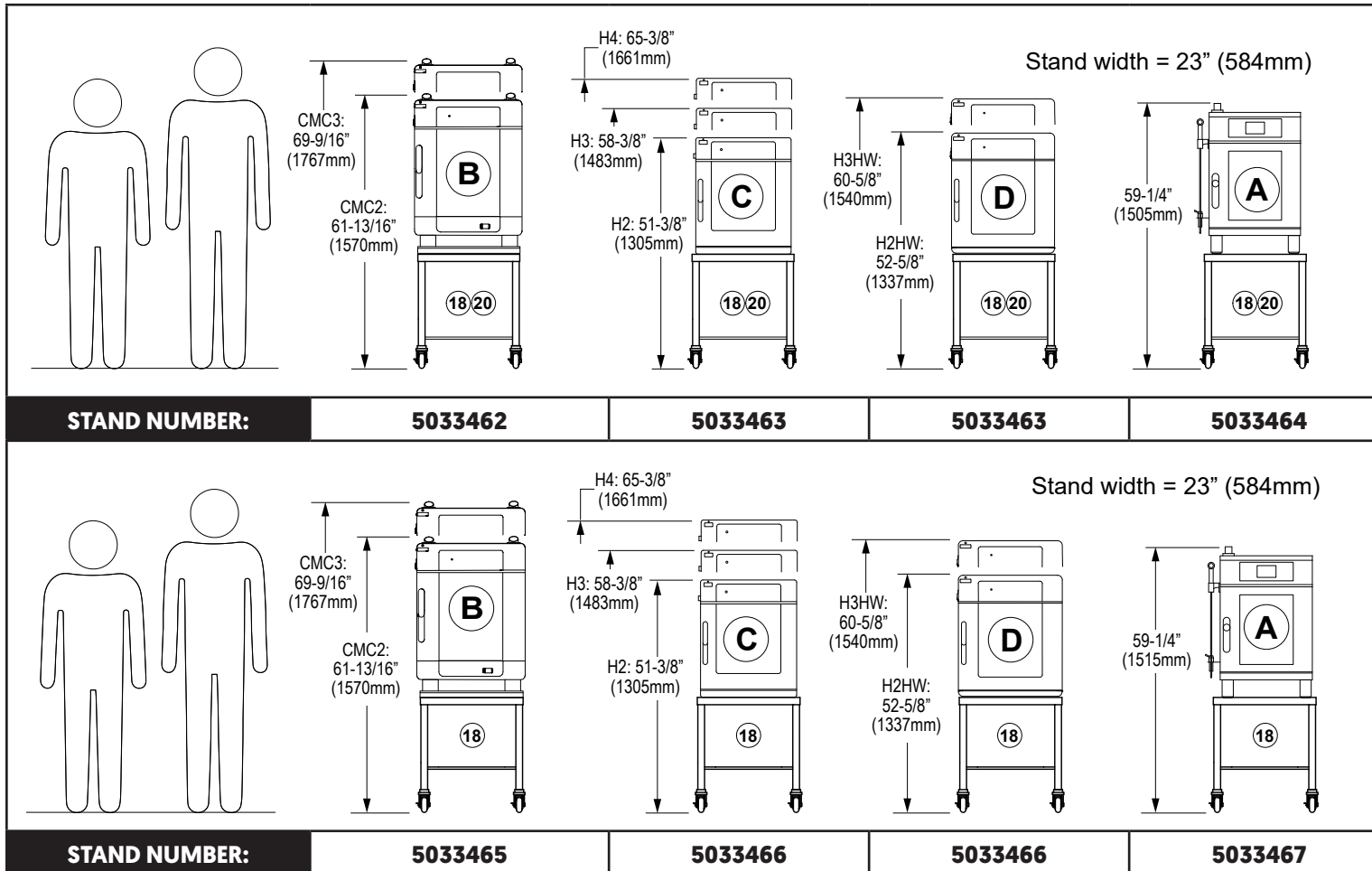

Combinations—23" (584mm) Wide Stands [continued]

Note: The human figures at left are provided for general height reference. They are depicted as 5'-5" [1651mm] and 6' [1829mm] tall.

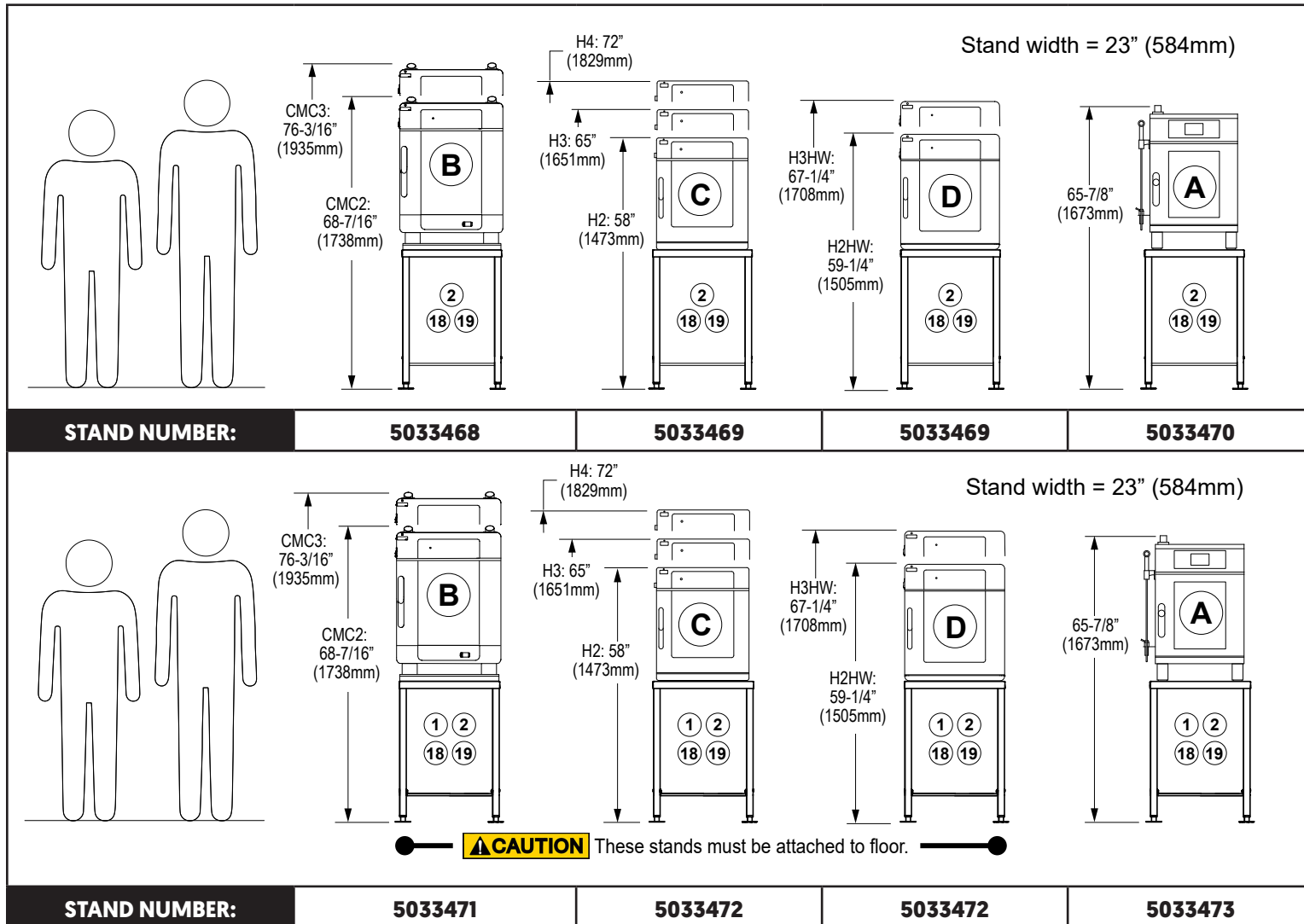

Combinations— 23" (584mm) Wide Stands [continued]

Note: The human figures at left are provided for general height reference. They are depicted as 5'-5" (1651mm) and 6' (1829mm) tall.

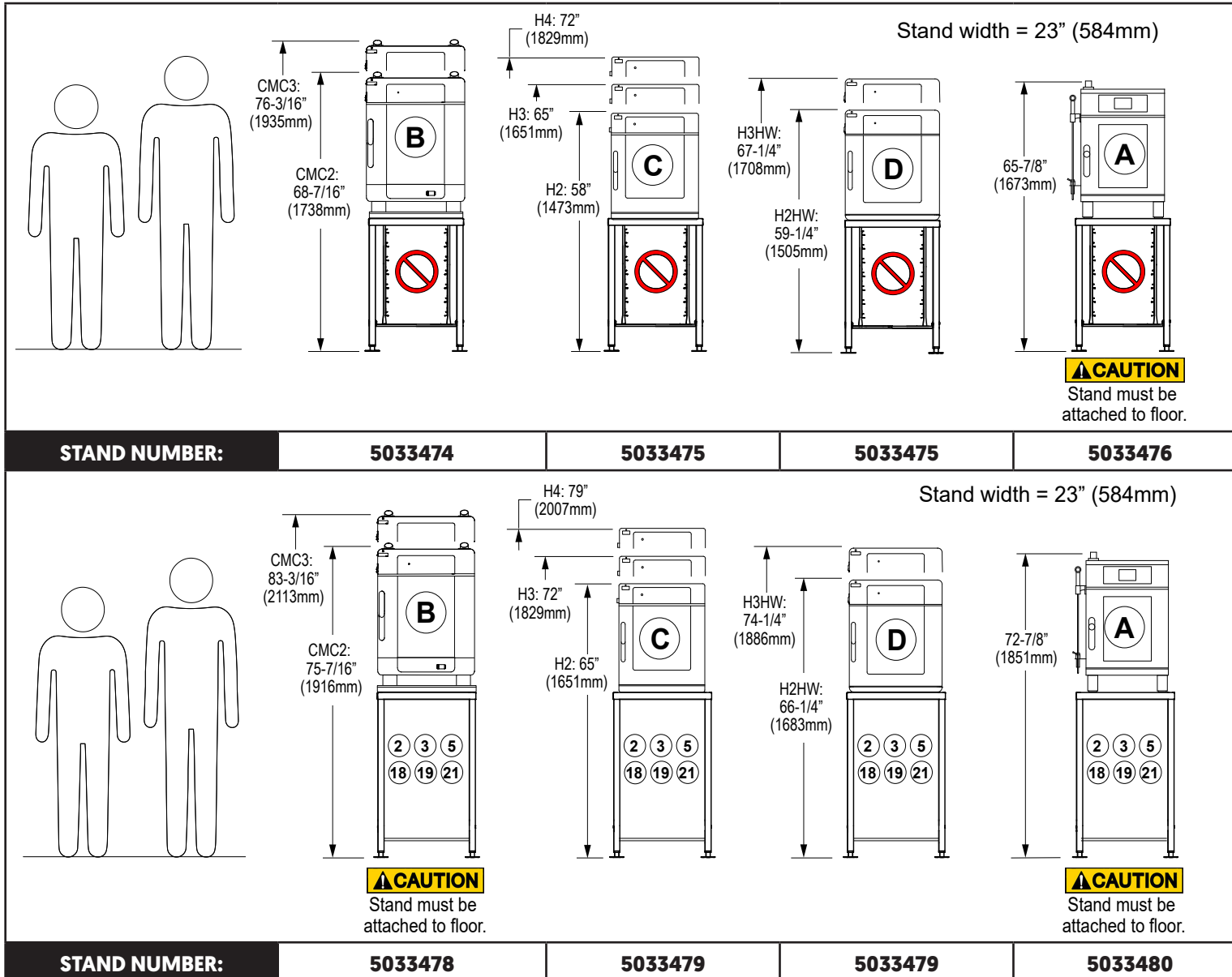

Combinations—23" (584mm) Wide Stands [continued]

Note: The human figures at left are provided for general height reference. They are depicted as 5'-5" (1651mm) and 6' (1829mm) tall.

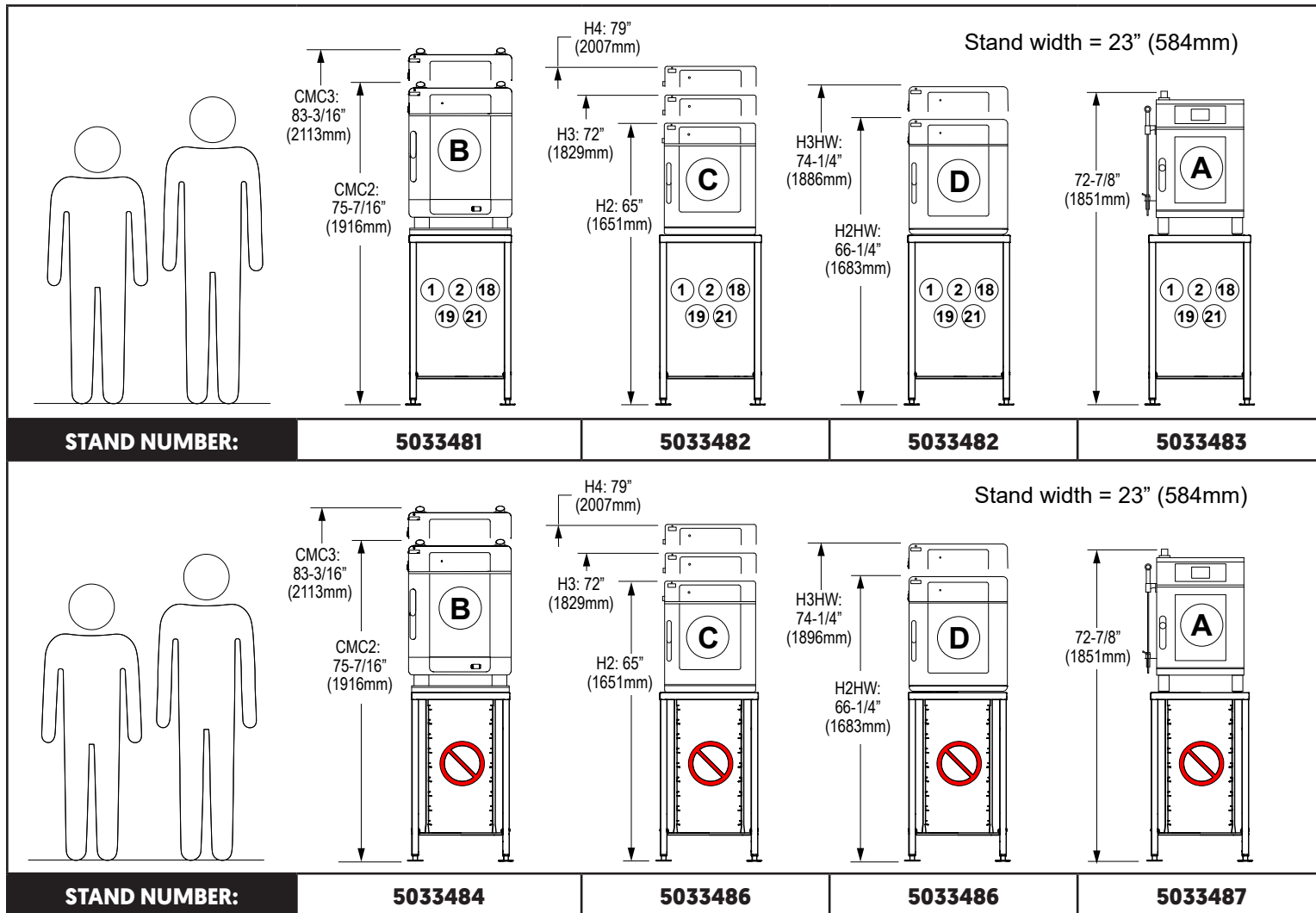

Combinations—23" (584mm) Wide Stands [continued]

Note: The human figures at left are provided for general height reference. They are depicted as 5'-5" (1651mm) and 6' (1829mm) tall.

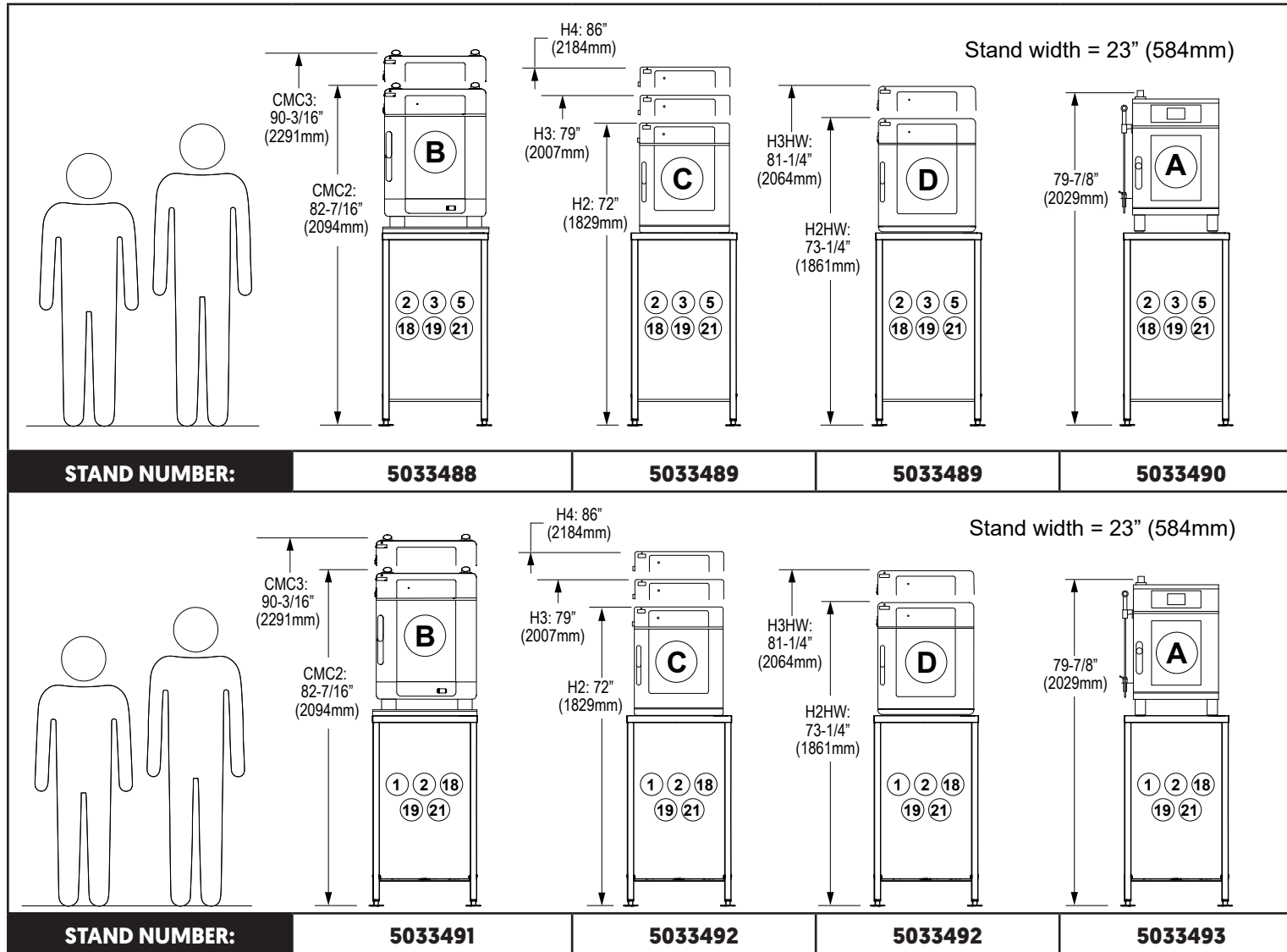

Combinations—23" (584mm) Wide Stands [continued]

Note: The human figures at left are provided for general height reference. They are depicted as 5'-5" (1651mm) and 6' (1829mm) tall.

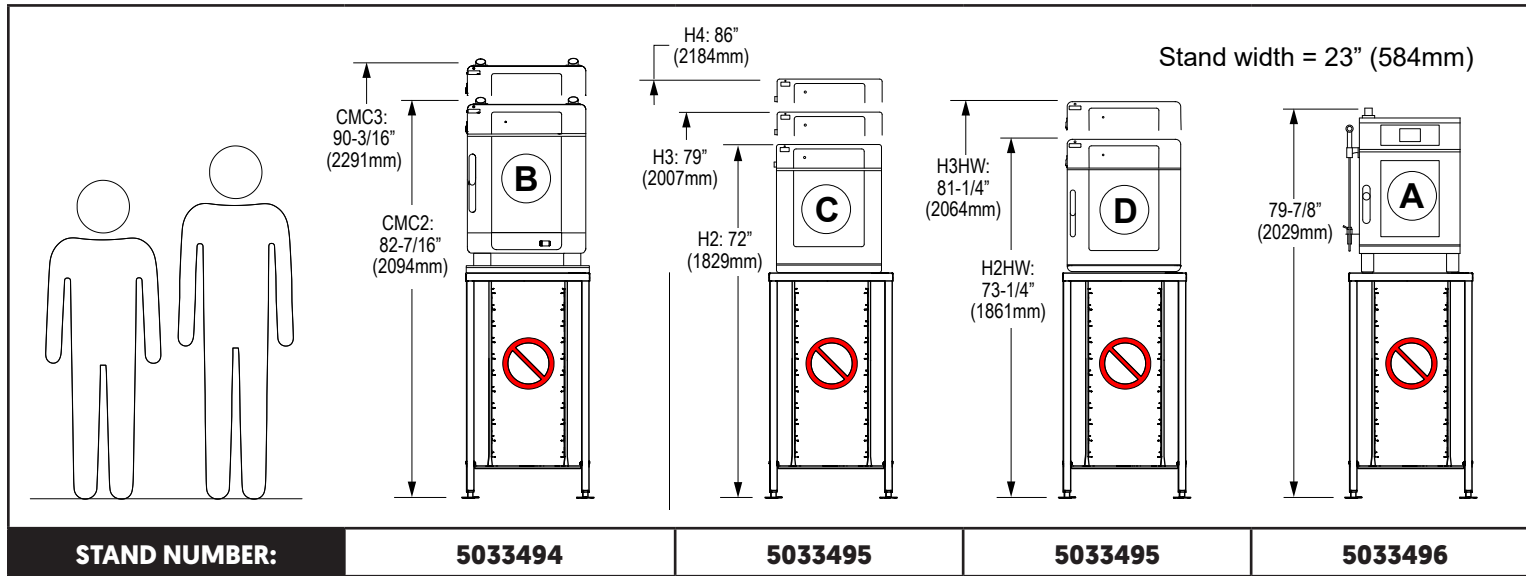

Combinations—25-1/2" (648mm) Wide Stands

Note: The human figures at left are provided for general height reference. They are depicted as 5'-5" [1651mm] and 6' [1829mm] tall.

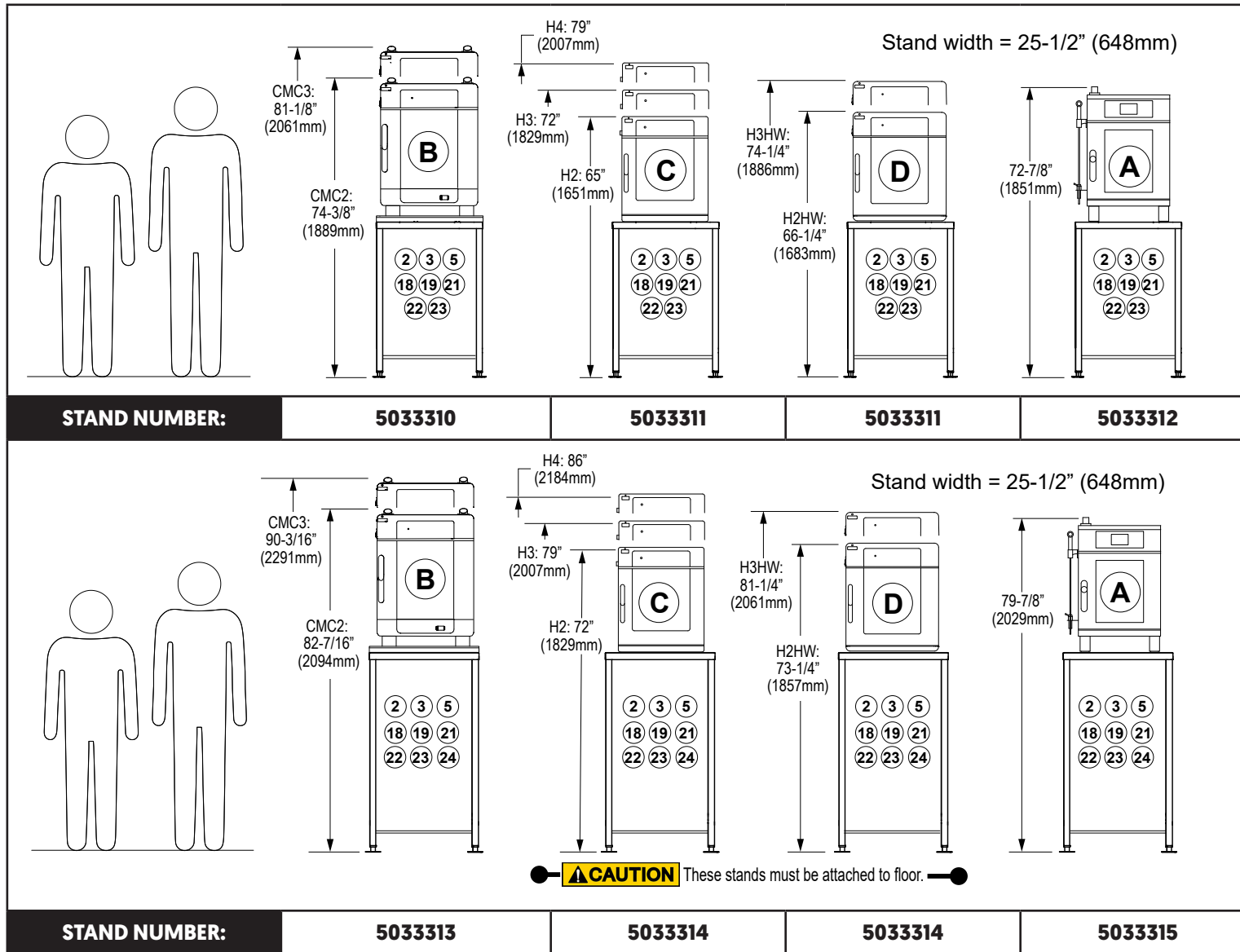

Combinations—25-1/2" (648mm) Wide Stands [continued]

Note: The human figures at left are provided for general height reference. They are depicted as 5'-5" [1651mm] and 6' [1829mm] tall.

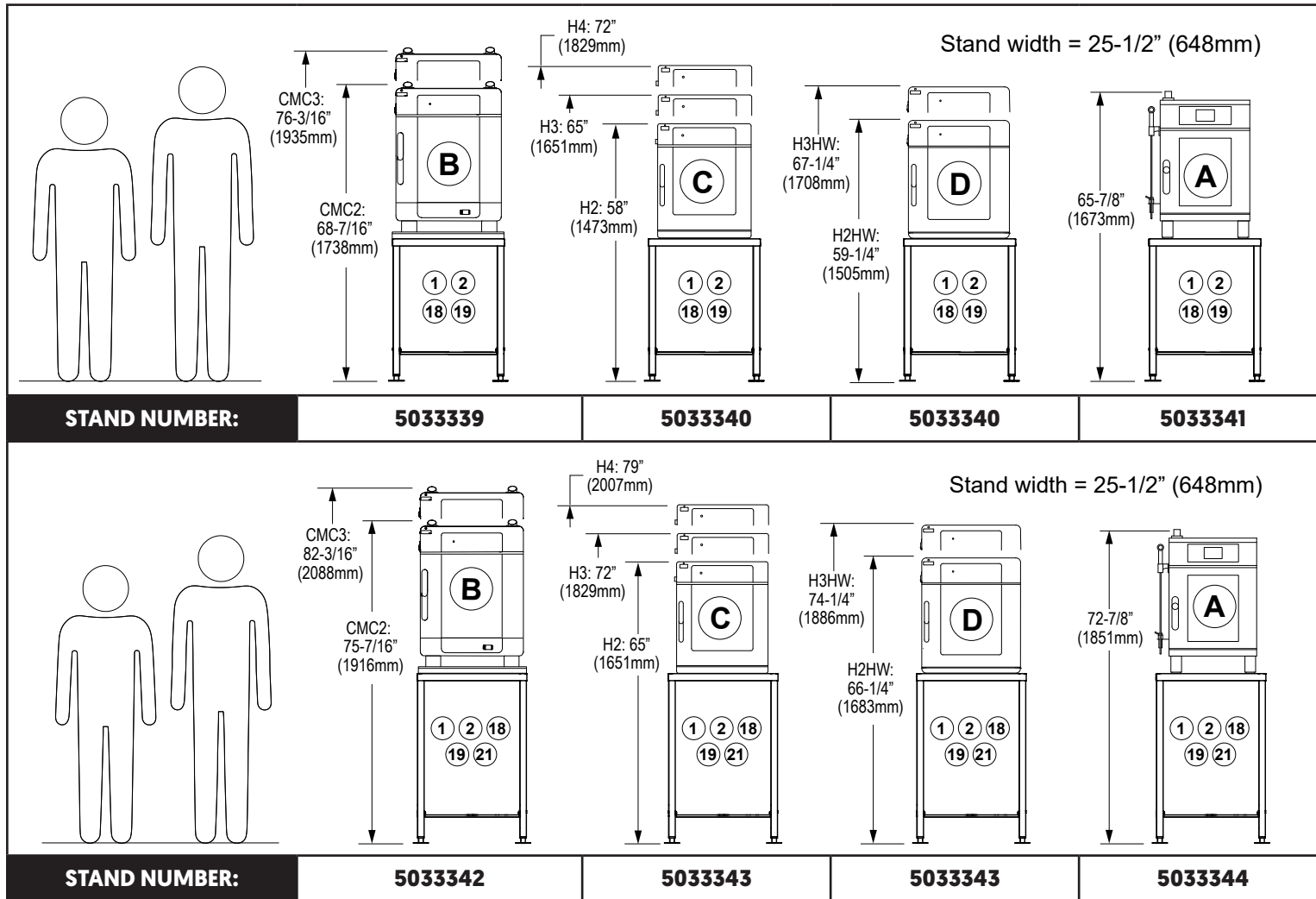

Combinations—25-1/2" (648mm) Wide Stands [continued]

Note: The human figures at left are provided for general height reference. They are depicted as 5'-5" [1651mm] and 6' [1829mm] tall.

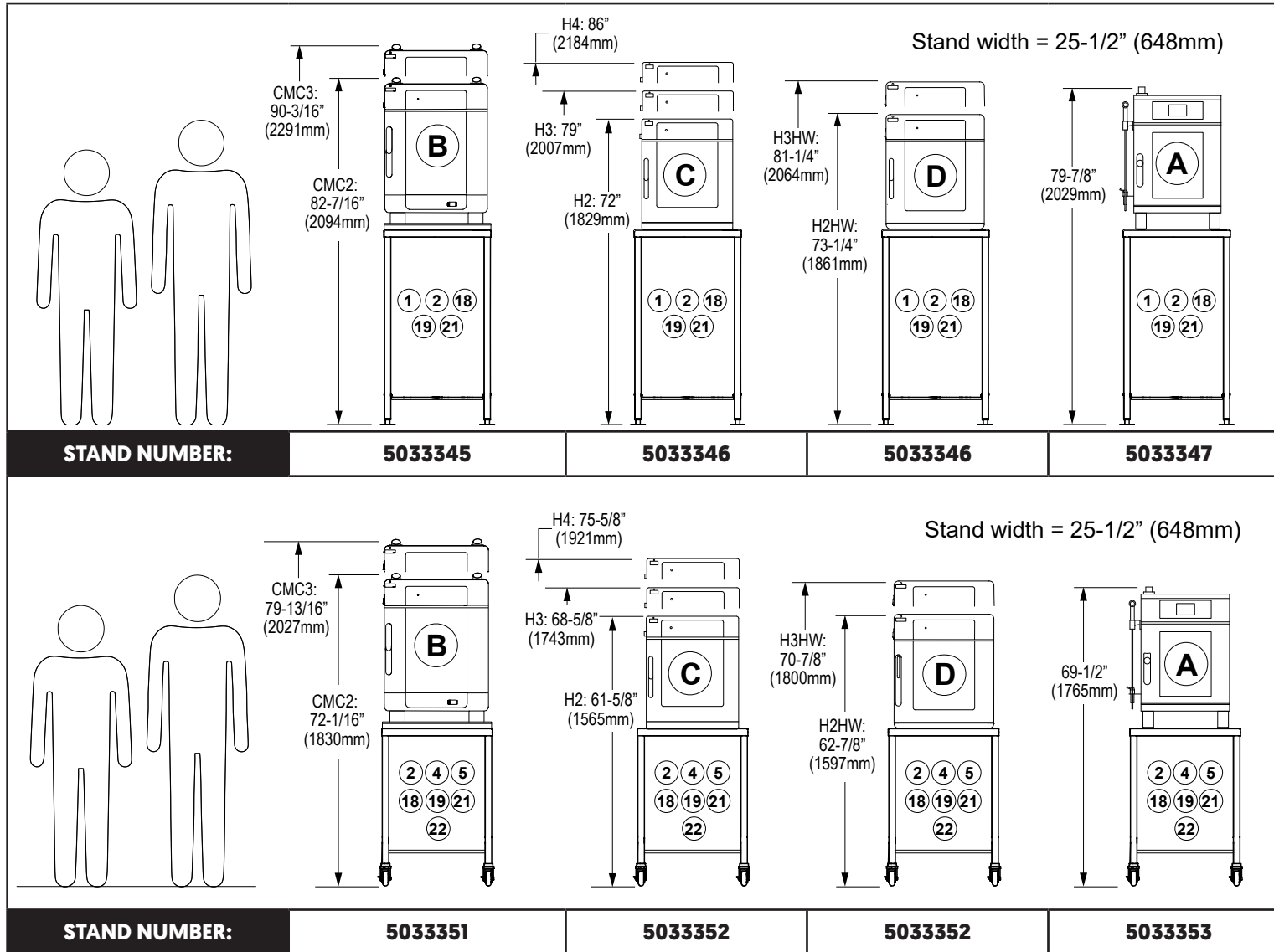

Combinations—25-1/2" (648mm) Wide Stands [continued]

Note: The human figures at left are provided for general height reference. They are depicted as 5'-5" (1651mm) and 6' (1829mm) tall.

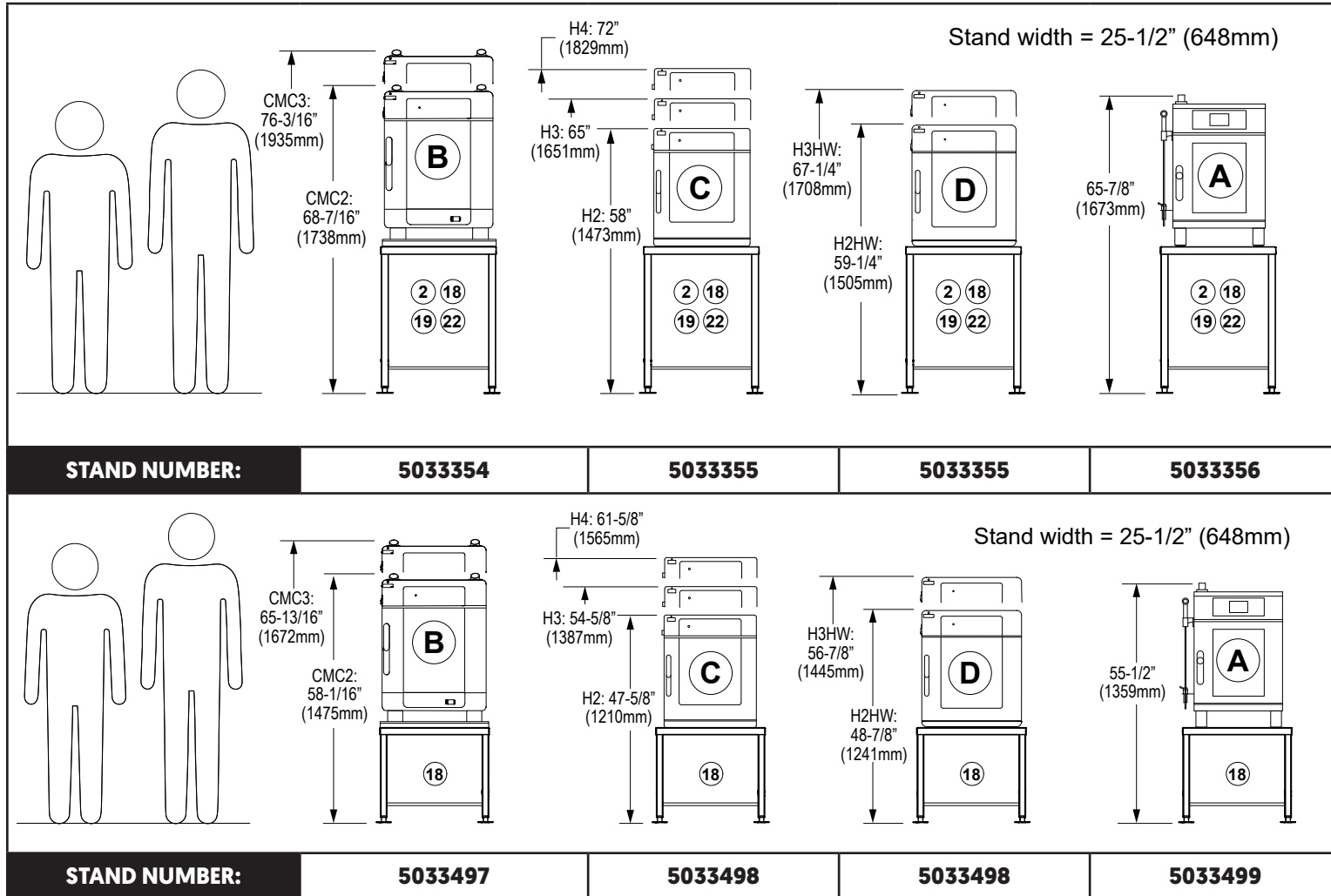

Combinations—25-1/2" (648mm) Wide Stands [continued]

Note: The human figures at left are provided for general height reference. They are depicted as 5'-5" [1651mm] and 6' [1829mm] tall.

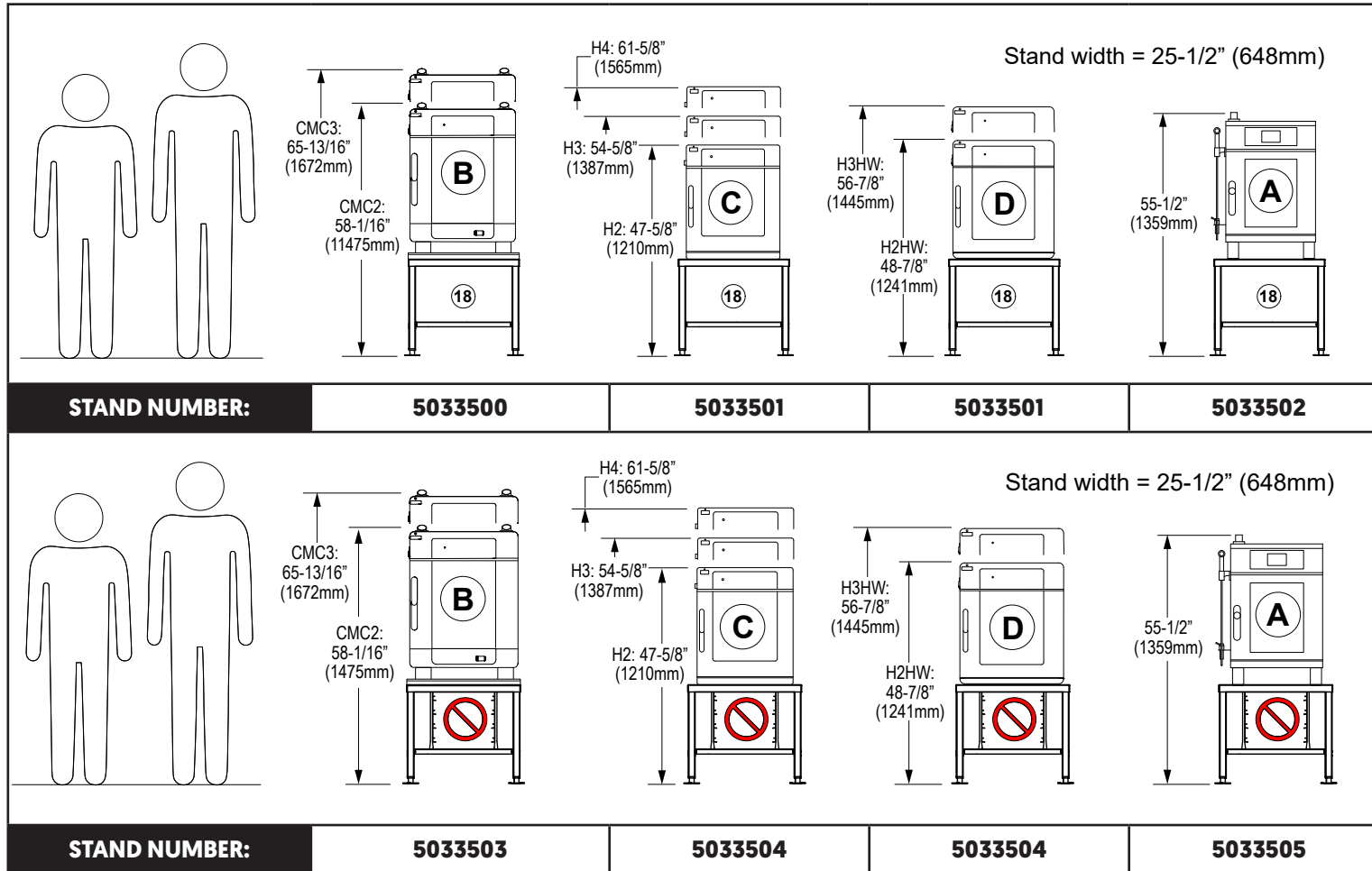

Combinations—25-1/2" (648mm) Wide Stands [continued]

Note: The human figures at left are provided for general height reference. They are depicted as 5'-5" (1651mm) and 6' (1829mm) tall.

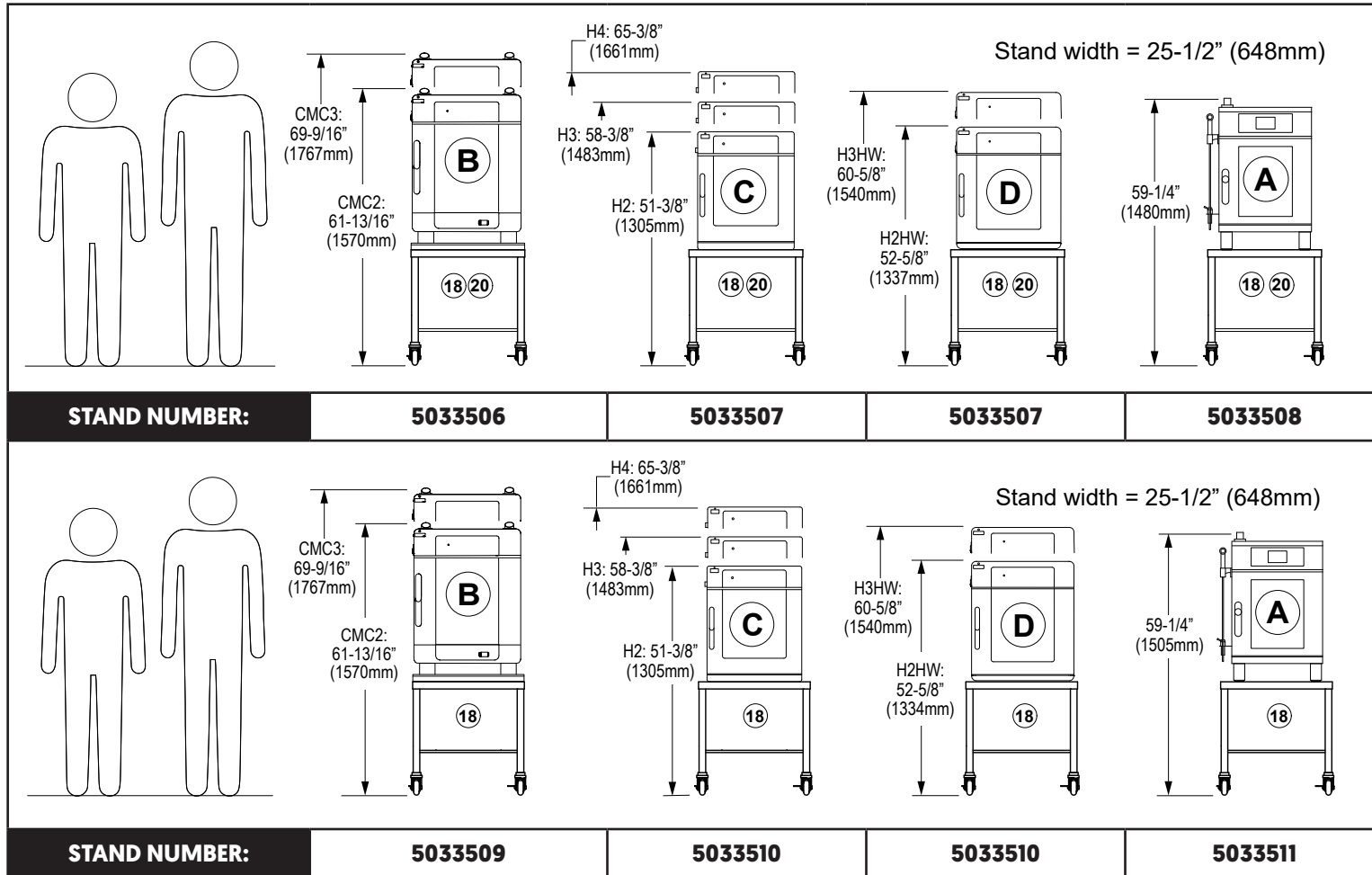

Combinations—25-1/2" (648mm) Wide Stands [continued]

Note: The human figures at left are provided for general height reference. They are depicted as 5'-5" [1651mm] and 6' [1829mm] tall.

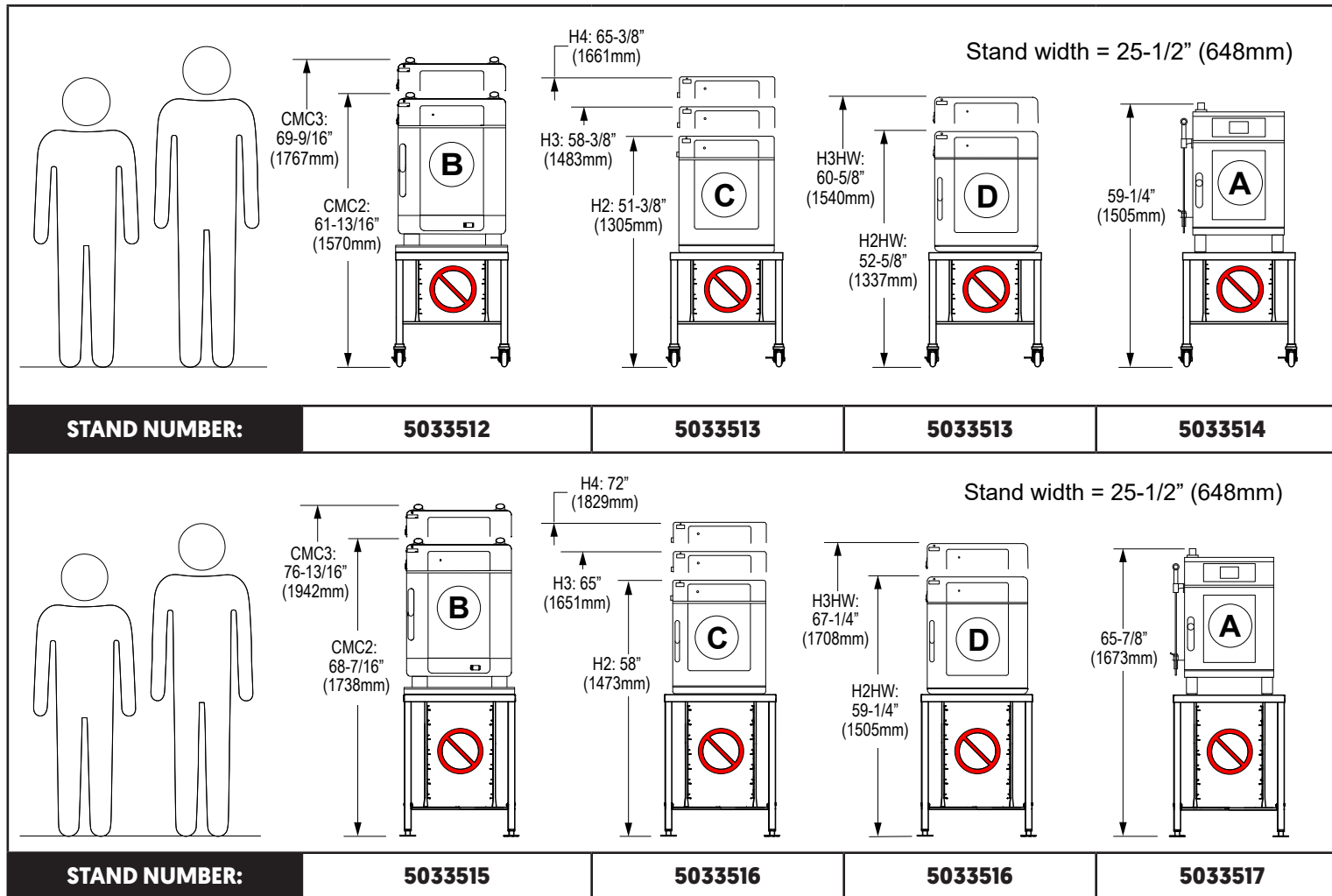

Combinations—25-1/2" (648mm) Wide Stands [continued]

Note: The human figures at left are provided for general height reference. They are depicted as 5'-5" [1651mm] and 6' [1829mm] tall.

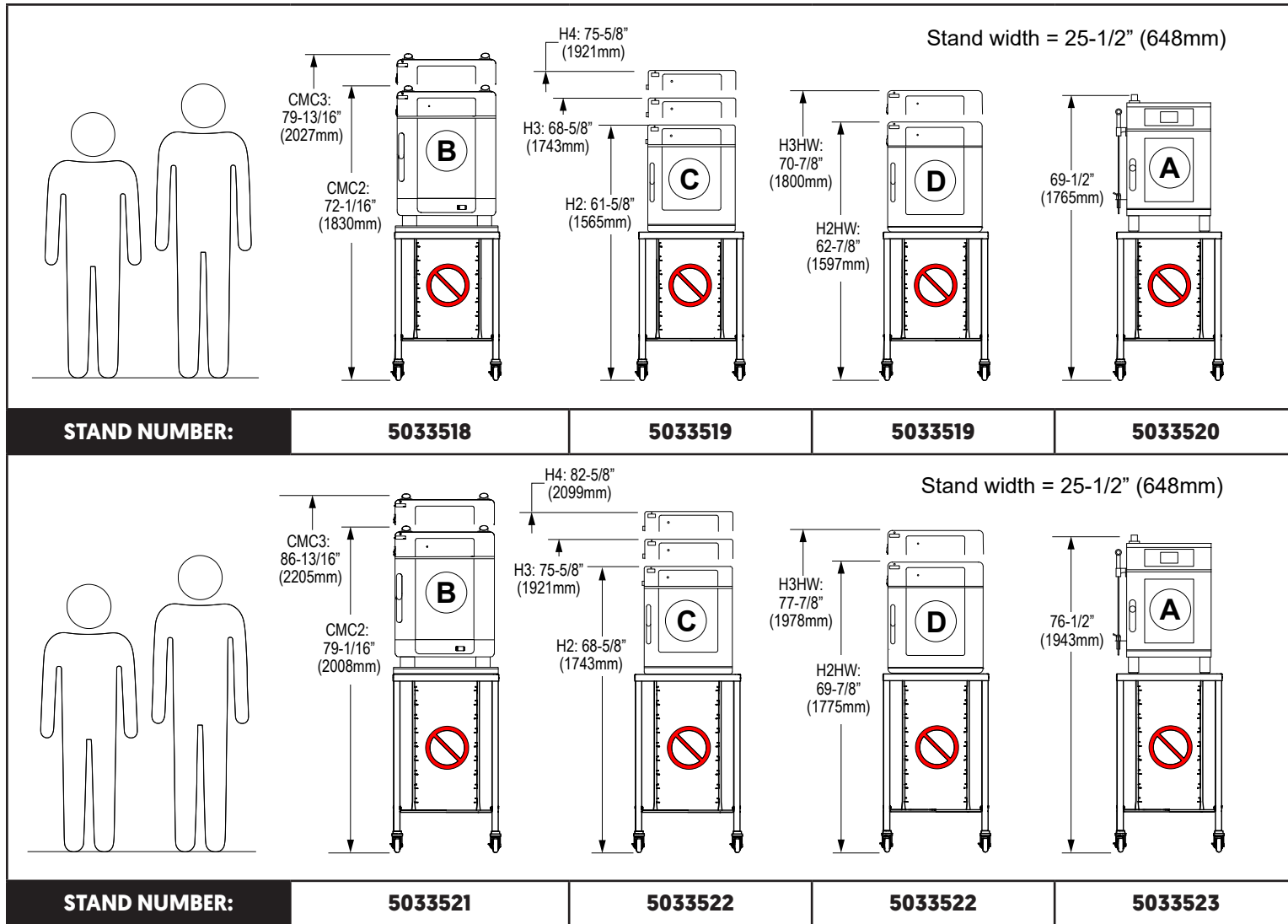

Combinations—25-1/2" (648mm) Wide Stands [continued]

Note: The human figures at left are provided for general height reference. They are depicted as 5'-5" (1651mm) and 6' (1829mm) tall.

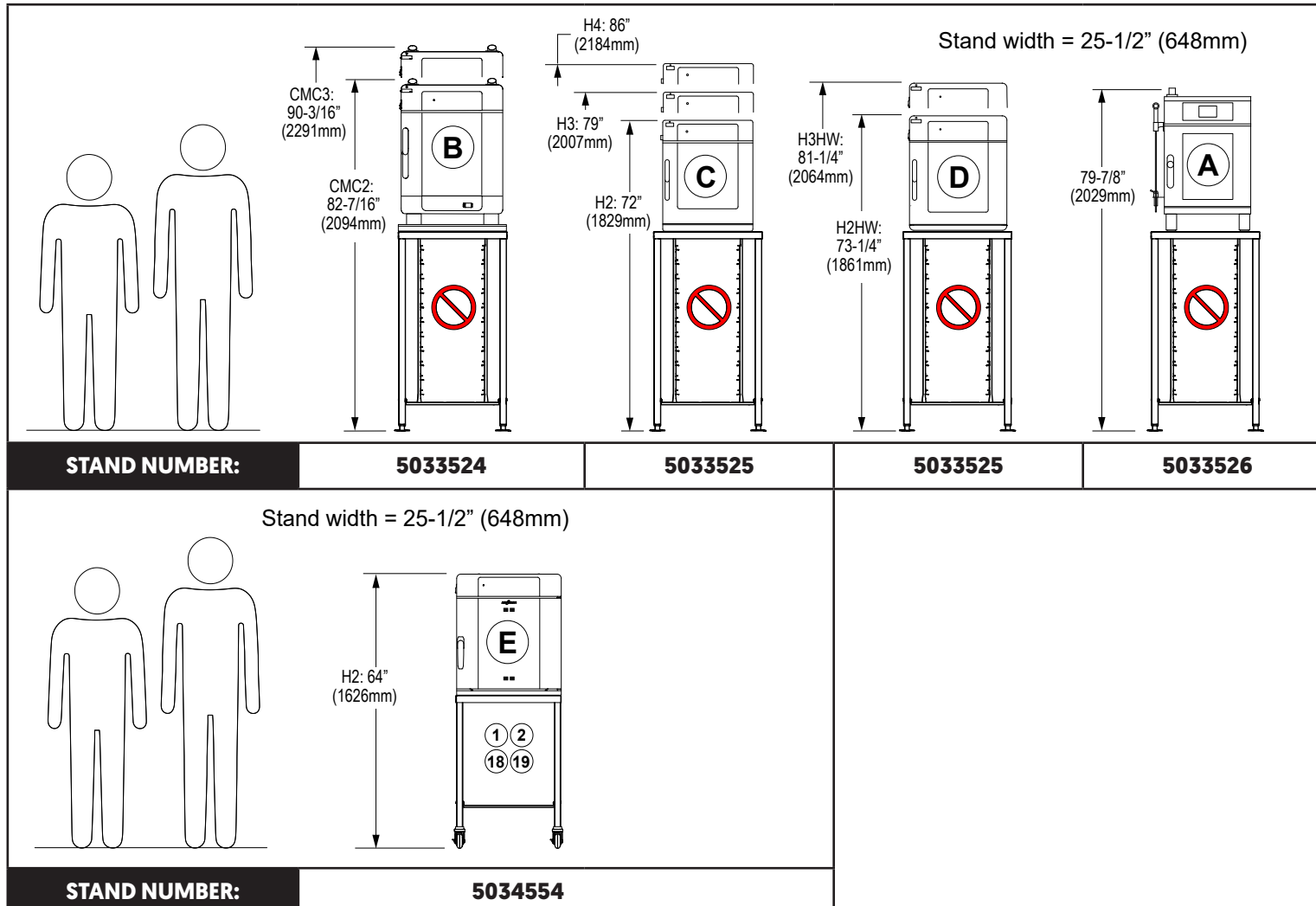

Combinations—25-1/2" (648mm) Wide Stands

Note: The human figures at left are provided for general height reference. They are depicted as 5'-5" [1651mm] and 6' [1829mm] tall.

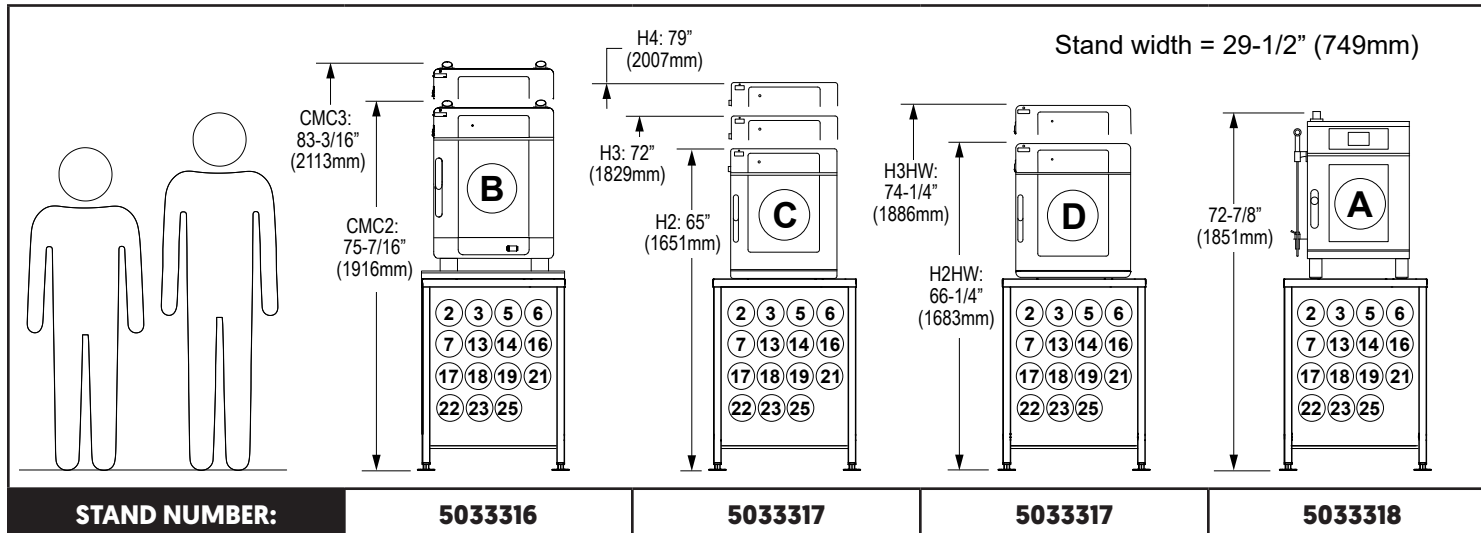

Combinations—29-1/2" (749mm) Wide Stands [continued]

Note: The human figures at left are provided for general height reference. They are depicted as 5'-5" [1651mm] and 6' [1829mm] tall.

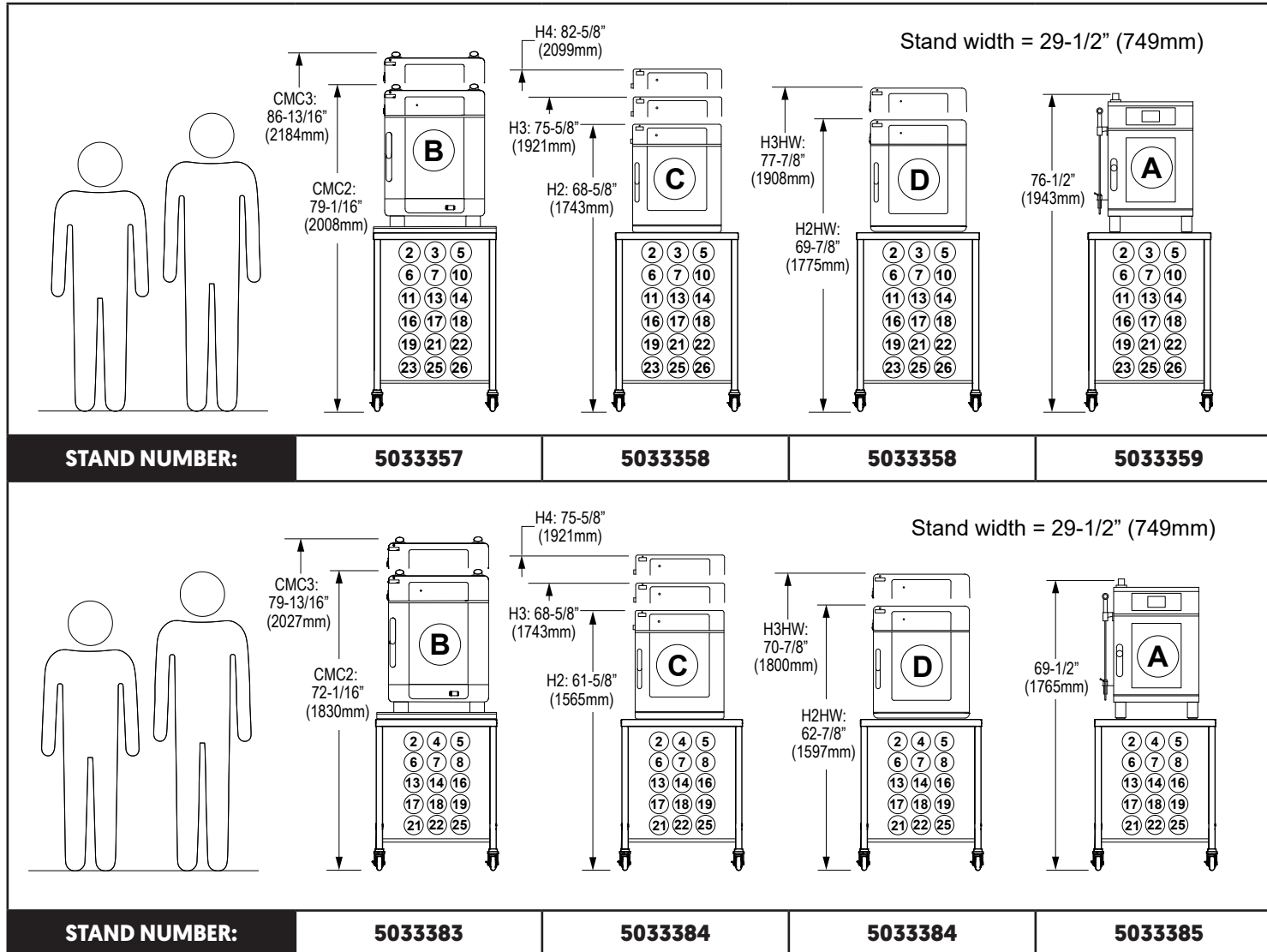

Combinations—29-1/2" (749mm) Wide Stands [continued]

Note: The human figures at left are provided for general height reference. They are depicted as 5'-5" [1651mm] and 6' [1829mm] tall.

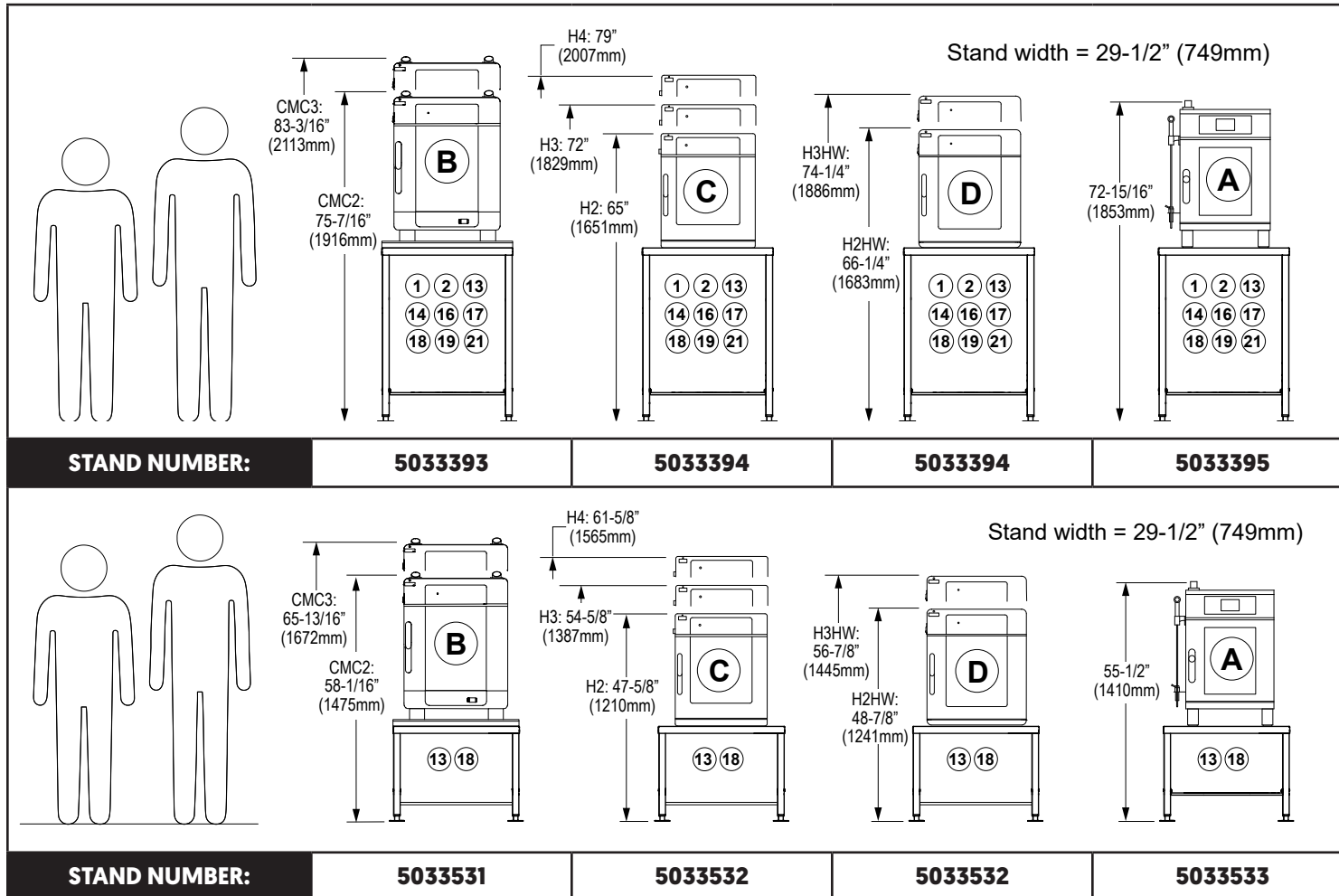

Combinations—29-1/2" (749mm) Wide Stands [continued]

Note: The human figures at left are provided for general height reference. They are depicted as 5'-5" (1651mm) and 6' (1829mm) tall.

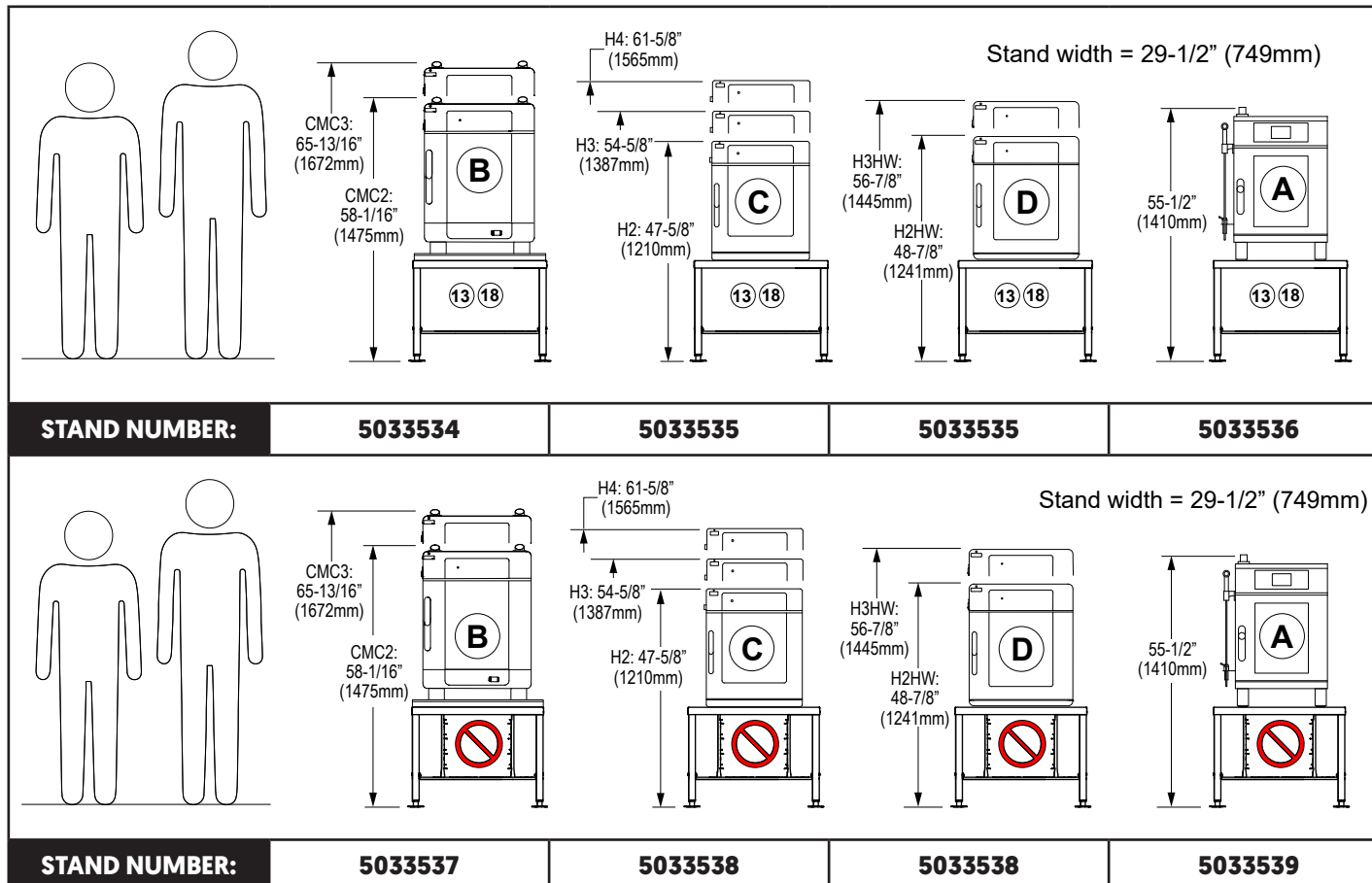

Combinations—29-1/2" (749mm) Wide Stands [continued]

Note: The human figures at left are provided for general height reference. They are depicted as 5'-5" (1651mm) and 6' (1829mm) tall.

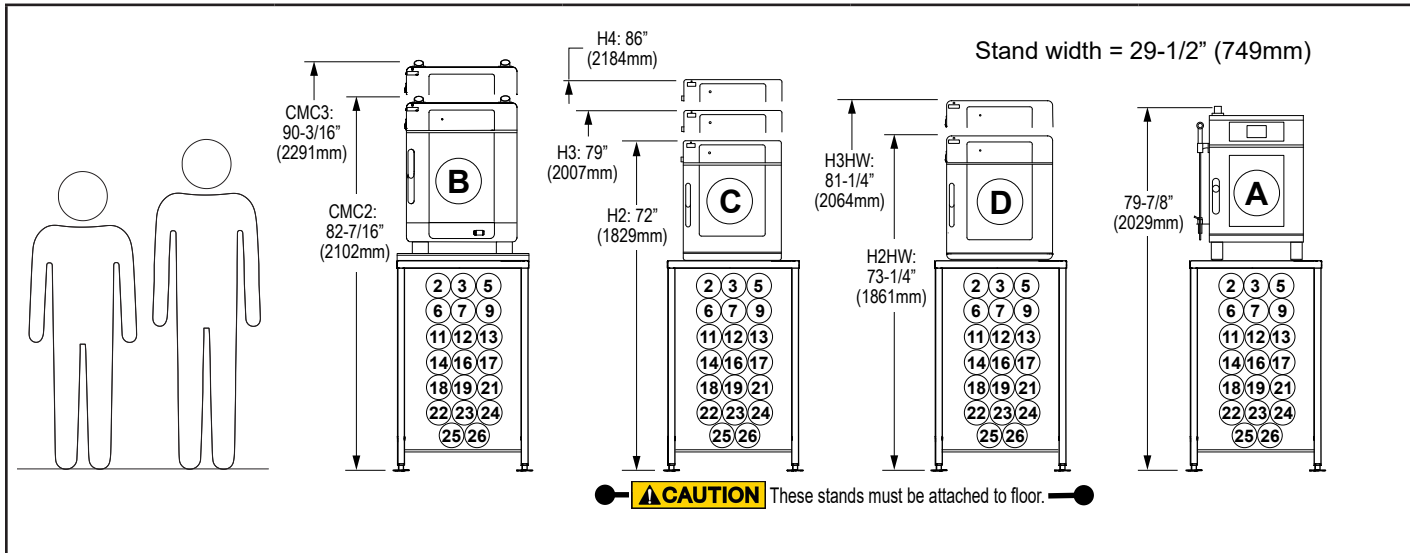

STAND NUMBER:	5033348	5033349	5033349	5033350
----------------------	----------------	----------------	----------------	----------------

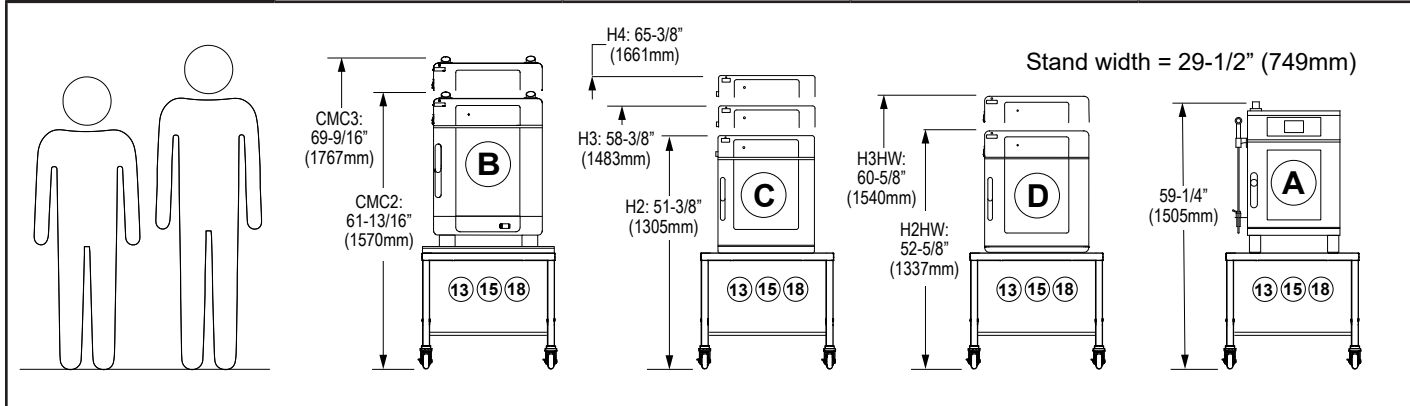

STAND NUMBER:	5033540	5033541	5033541	5033542
----------------------	----------------	----------------	----------------	----------------

Combinations—29-1/2" (749mm) Wide Stands [continued]

Note: The human figures at left are provided for general height reference. They are depicted as 5'-5" (1651mm) and 6' (1829mm) tall.

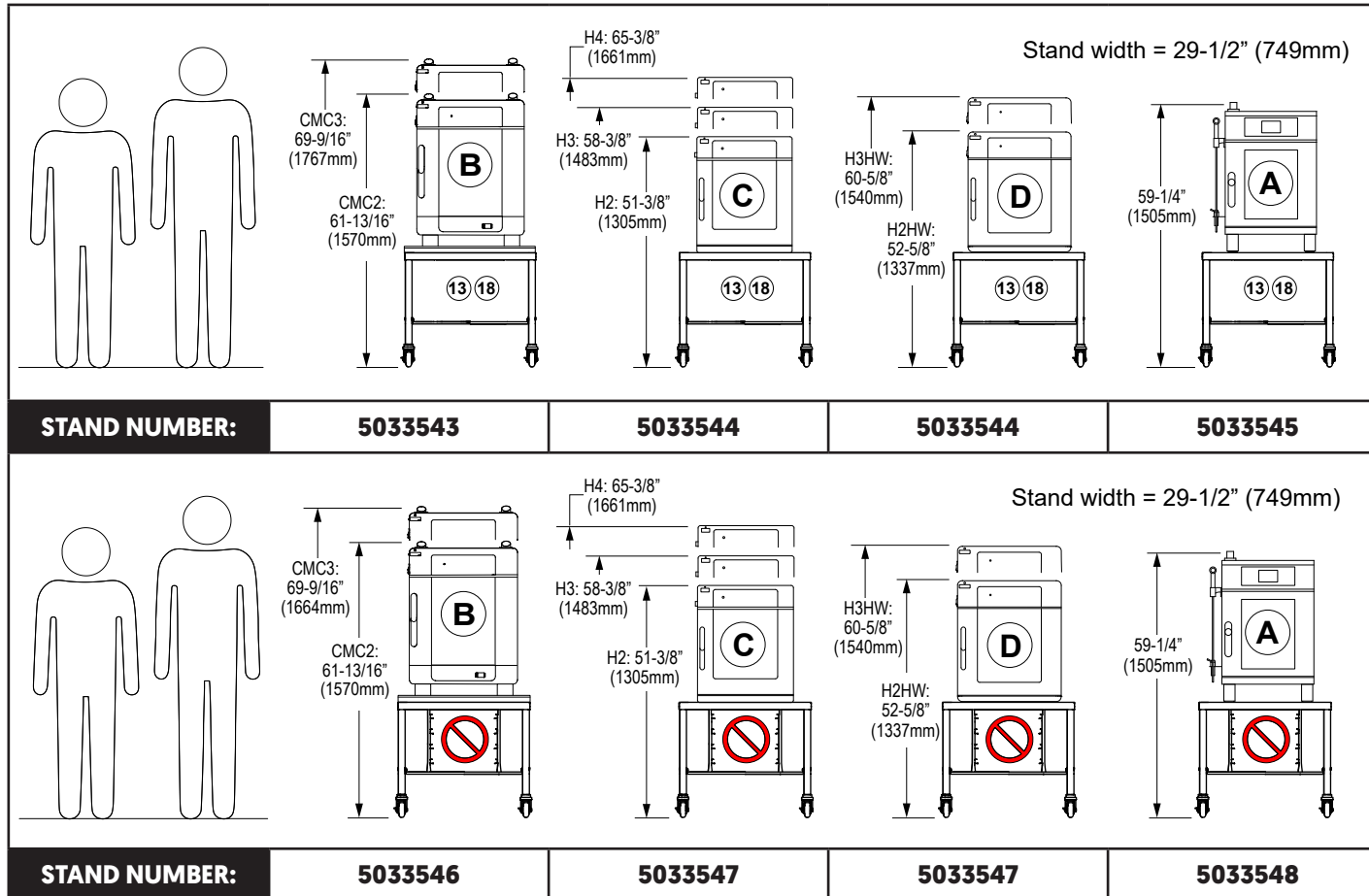

Combinations—29-1/2" [749mm] Wide Stands [continued]

Note: The human figures at left are provided for general height reference. They are depicted as 5'-5" [1651mm] and 6' [1829mm] tall.

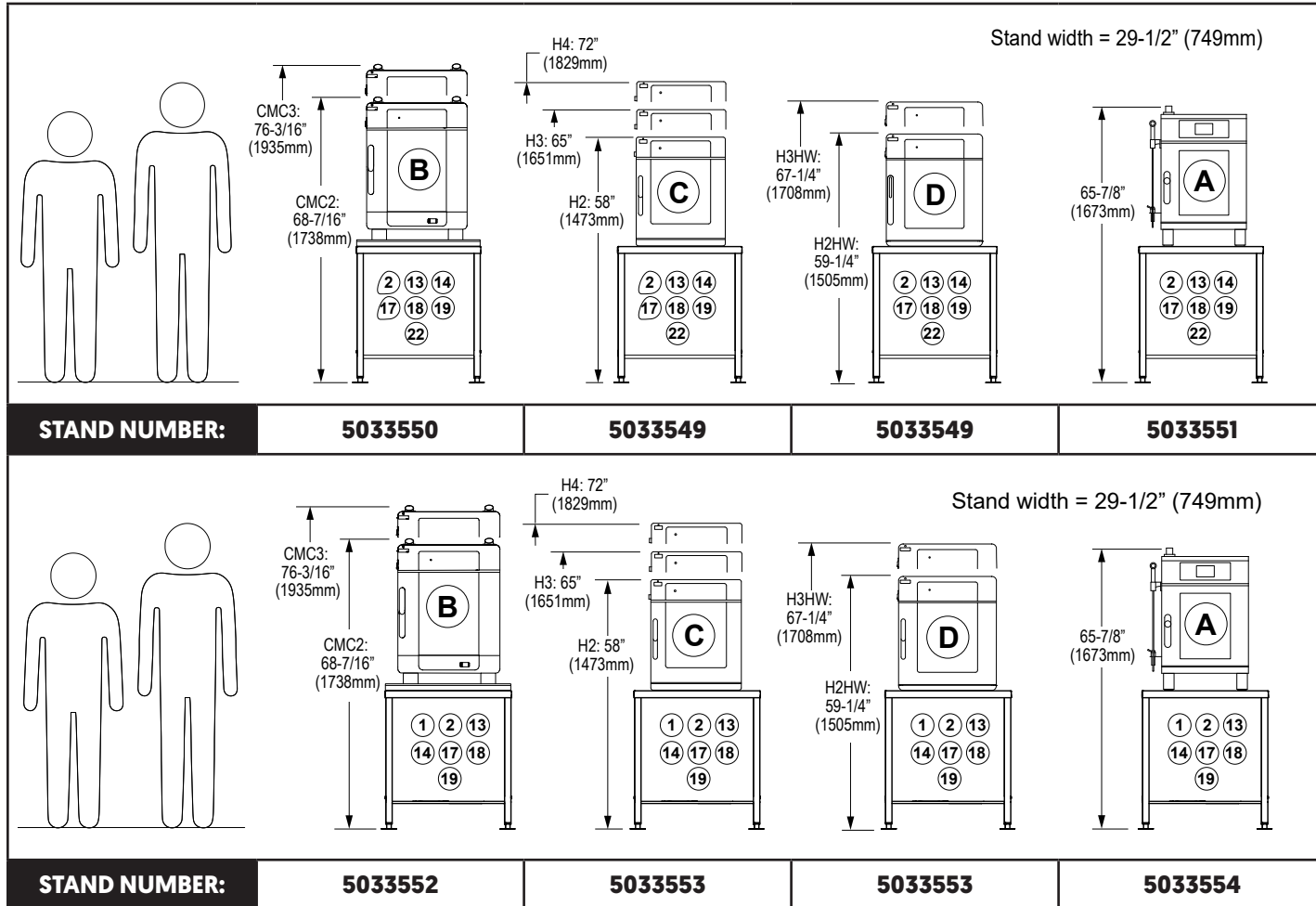

Combinations—29-1/2" (749mm) Wide Stands [continued]

Note: The human figures at left are provided for general height reference. They are depicted as 5'-5" [1651mm] and 6' [1829mm] tall.

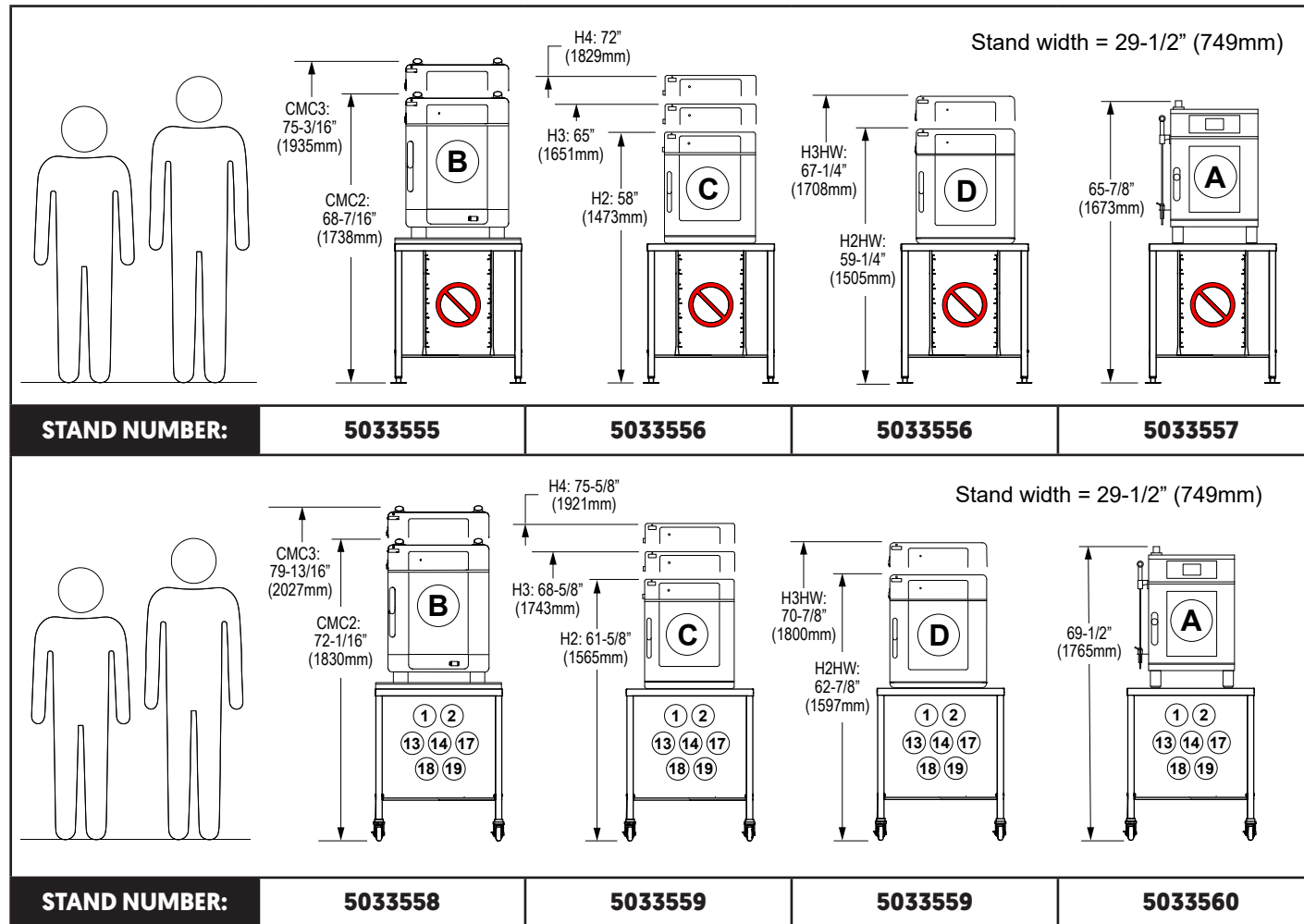

Combinations—29-1/2" (749mm) Wide Stands [continued]

Note: The human figures at left are provided for general height reference. They are depicted as 5'-5" (1651mm) and 6' (1829mm) tall.

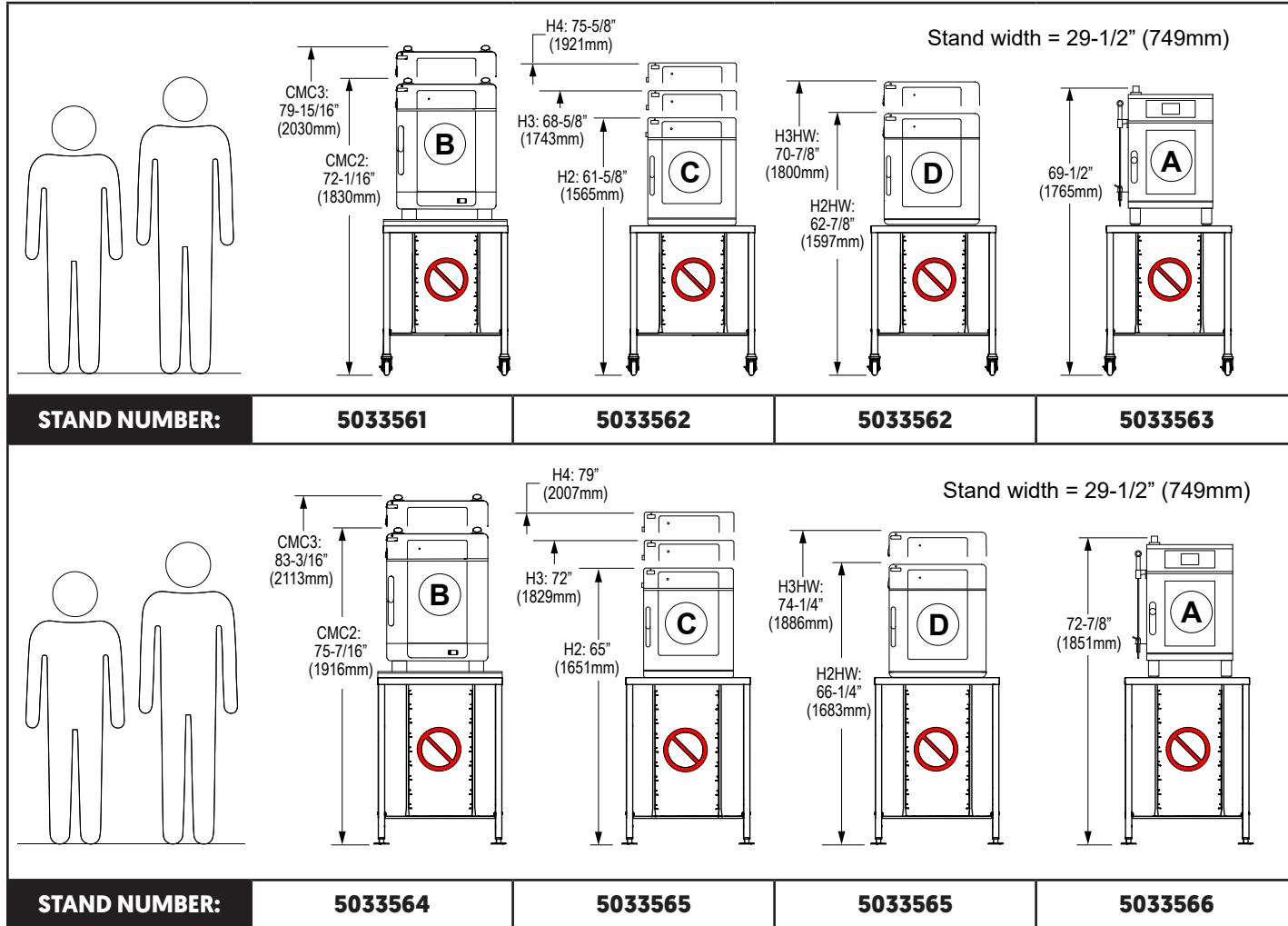

Combinations—29-1/2" (749mm) Wide Stands [continued]

Note: The human figures at left are provided for general height reference. They are depicted as 5'-5" [1651mm] and 6' [1829mm] tall.

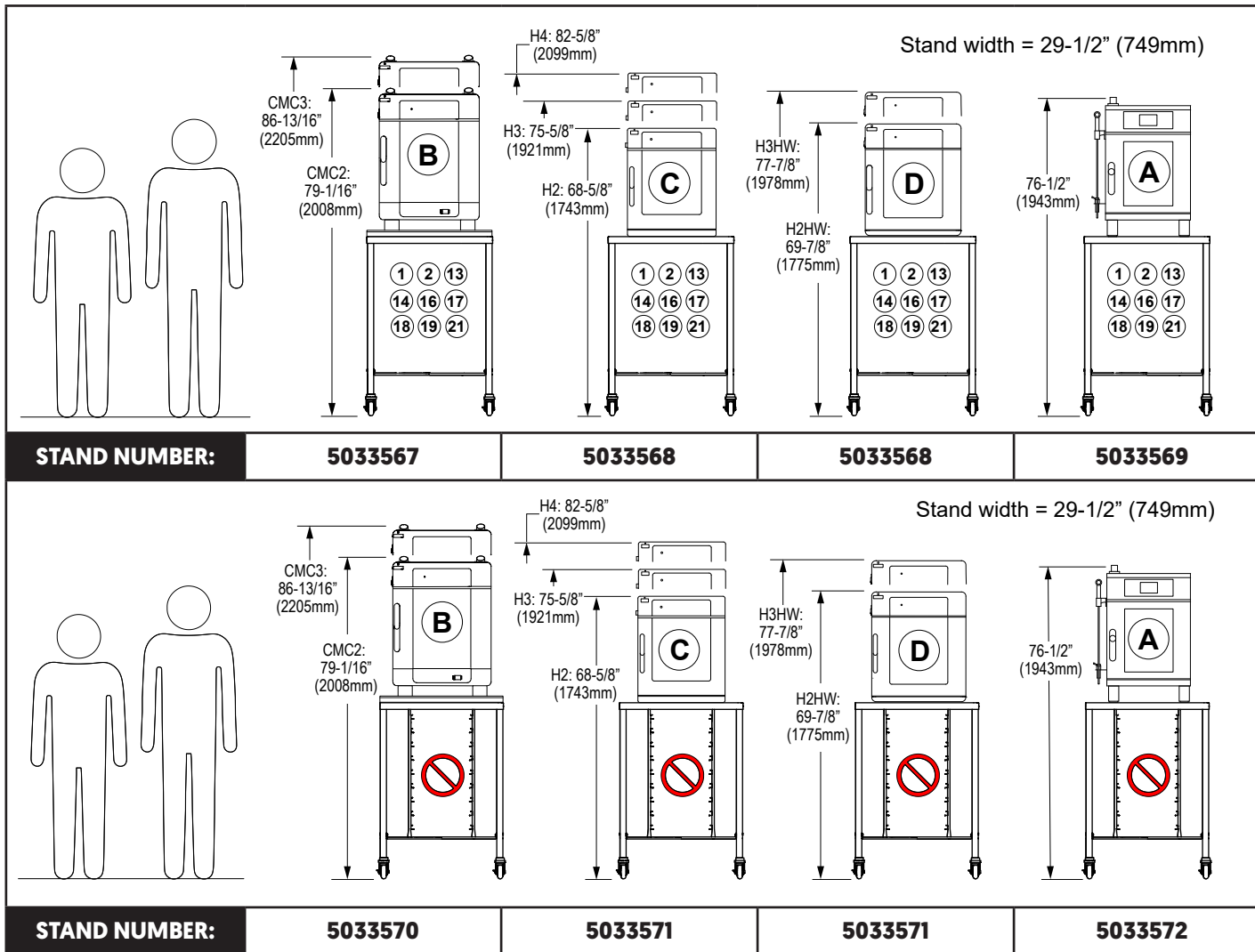

Combinations—29-1/2" (749mm) Wide Stands [continued]

Note: The human figures at left are provided for general height reference. They are depicted as 5'-5" (1651mm) and 6' (1829mm) tall.

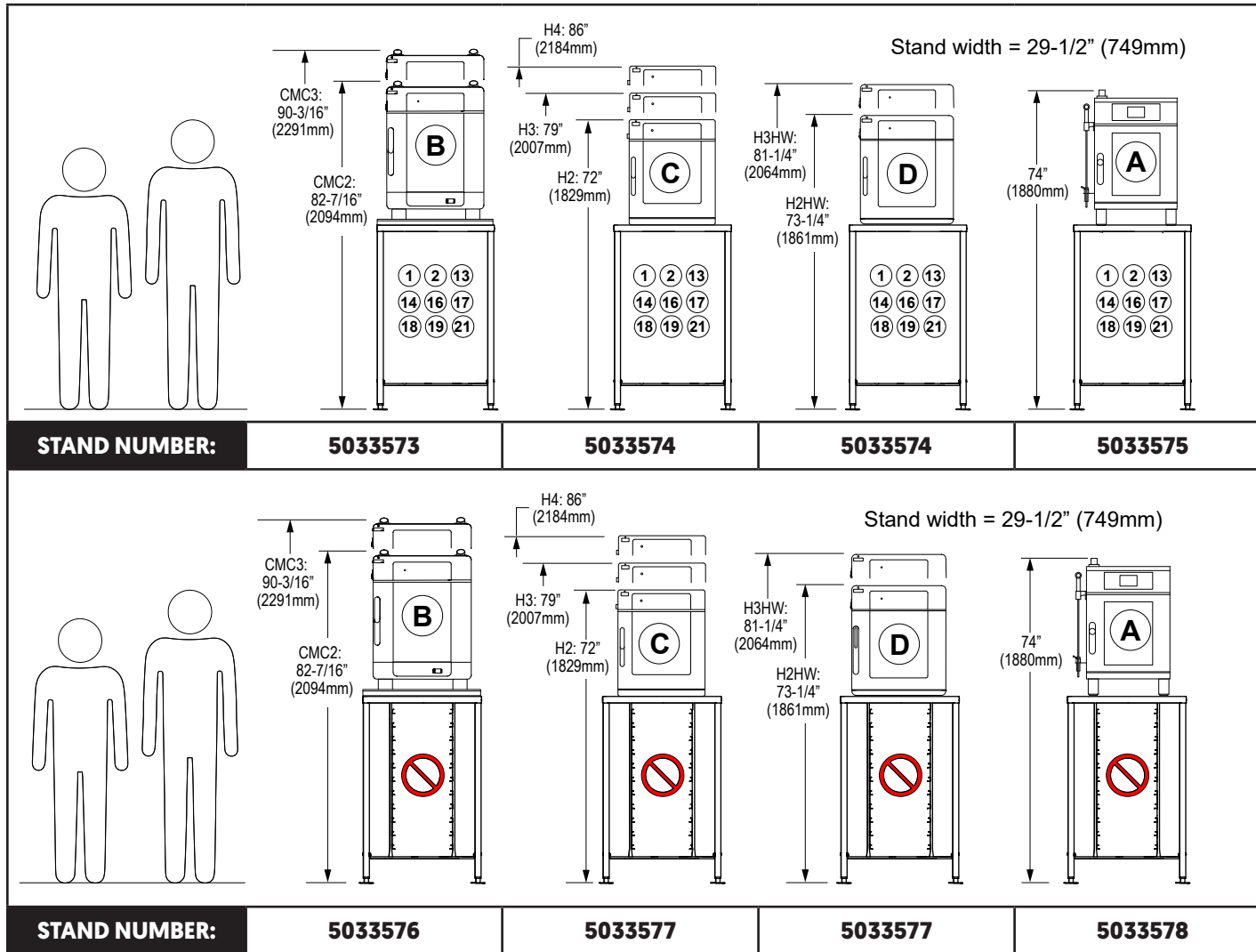

Stand Details

Universal stand kits are offered in three variations. Each variation includes the stand and unique hardware required to attach a specific oven to the stand.

Oven	Attachment Method
Converge (CMC)	Legs fit inside two metal rails, with pins at each end to center the oven
Vector H and Vector Wide 750-TH / 750-SK	Four screws from beneath, directly into oven base
CTX 4-10E	Each leg is centered between two pins

Etched letters on the universal stand top panel identify the specific hardware attachment locations for each type of oven. Refer to SRV-20196.

NOTE: Pages 51 and 52 depict a series of narrow stands exclusively designed for Vector H ovens. The top panel illustrated below includes only four holes. The holes align with existing threaded bolt holes on the underside of the Vector H.

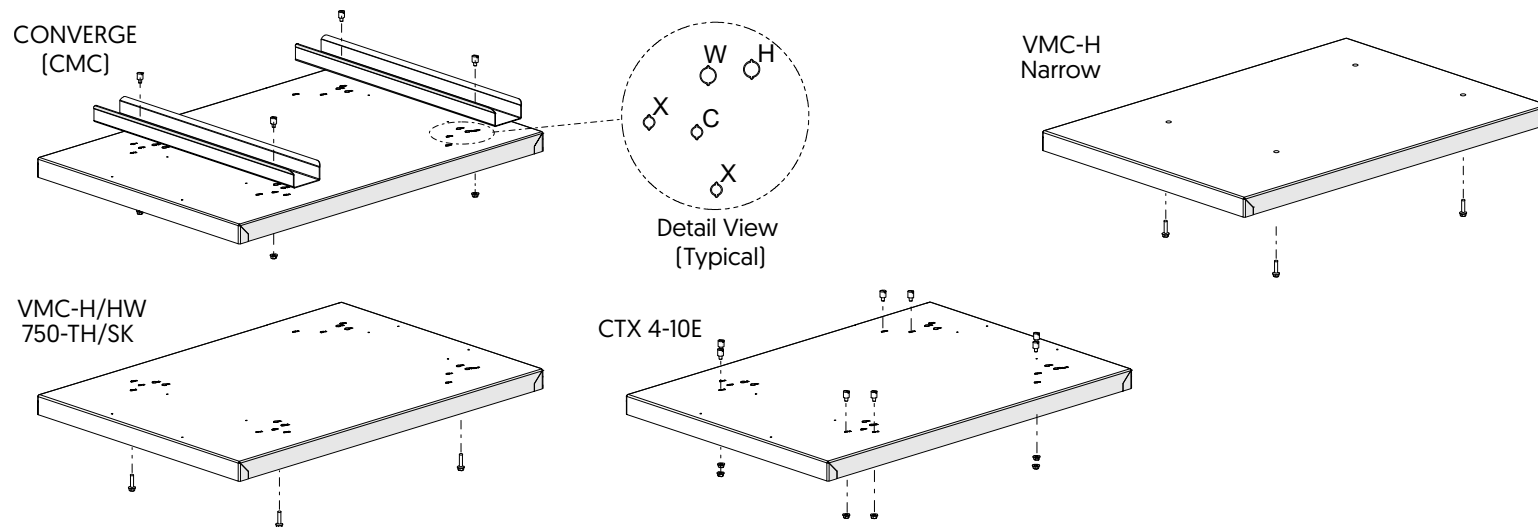

Stand Details [continued]

Stands equipped with side racks allow the user to set the side racks at two different widths to accommodate pans or Vector multi-cook oven jet plates. The right side rack can be moved 2" [51mm] inward if desired. See the illustration below.

To move the right side rack:

- 1) Raise the rack above the lower shelf and rotate it toward the center of the stand until the top tabs are free.
- 2) Shift the top tabs to the inner slots on the underside of the top panel. Insert the top tabs into the inner slots.
- 3) Finally, rotate the rack back to the vertical position and lower it into the inner slots on the lower shelf.

Refer to service document SRV-20196 for additional help if necessary.

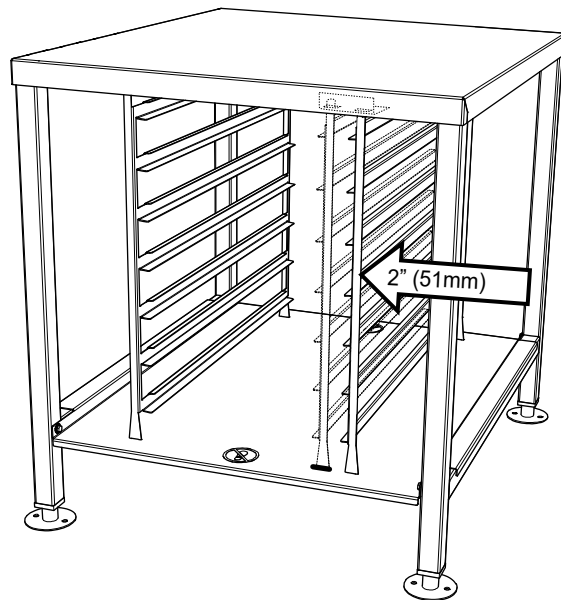

Stand Details [continued]

Dimensional views of each stand are provided below and on the following pages.
 For stands accommodating various ovens, the first number listed in each cell below is for the Converge (CMC) variation.
 The second number is for the Vector H/Vector Wide variation, and the third number is for the CTX variation.

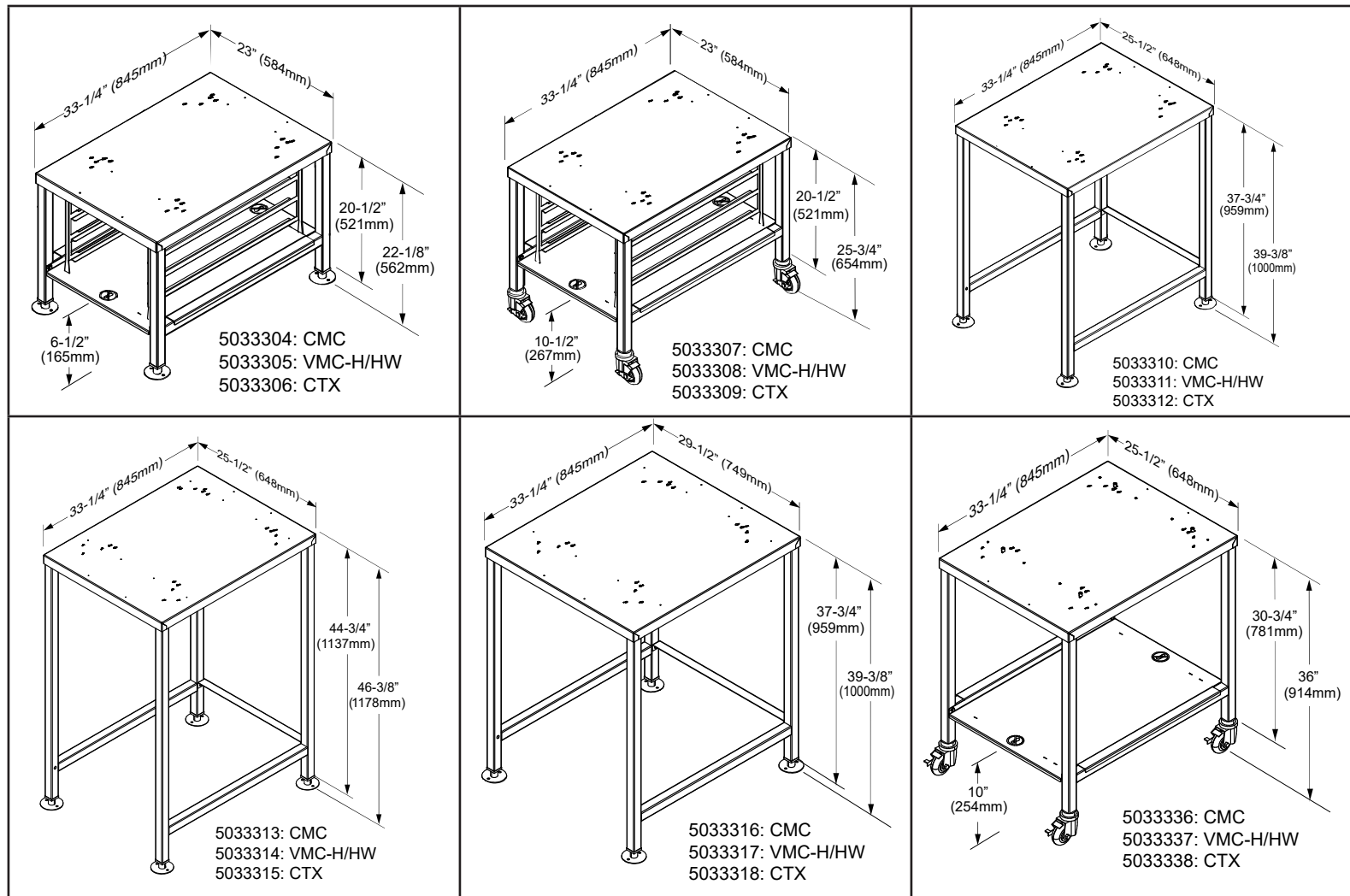

Stand Details [continued]

For stands accommodating various ovens, the first number listed in each cell below is for the Converge [CMC] variation. The second number is for the Vector H/Vector Wide variation, and the third number is for the CTX variation.

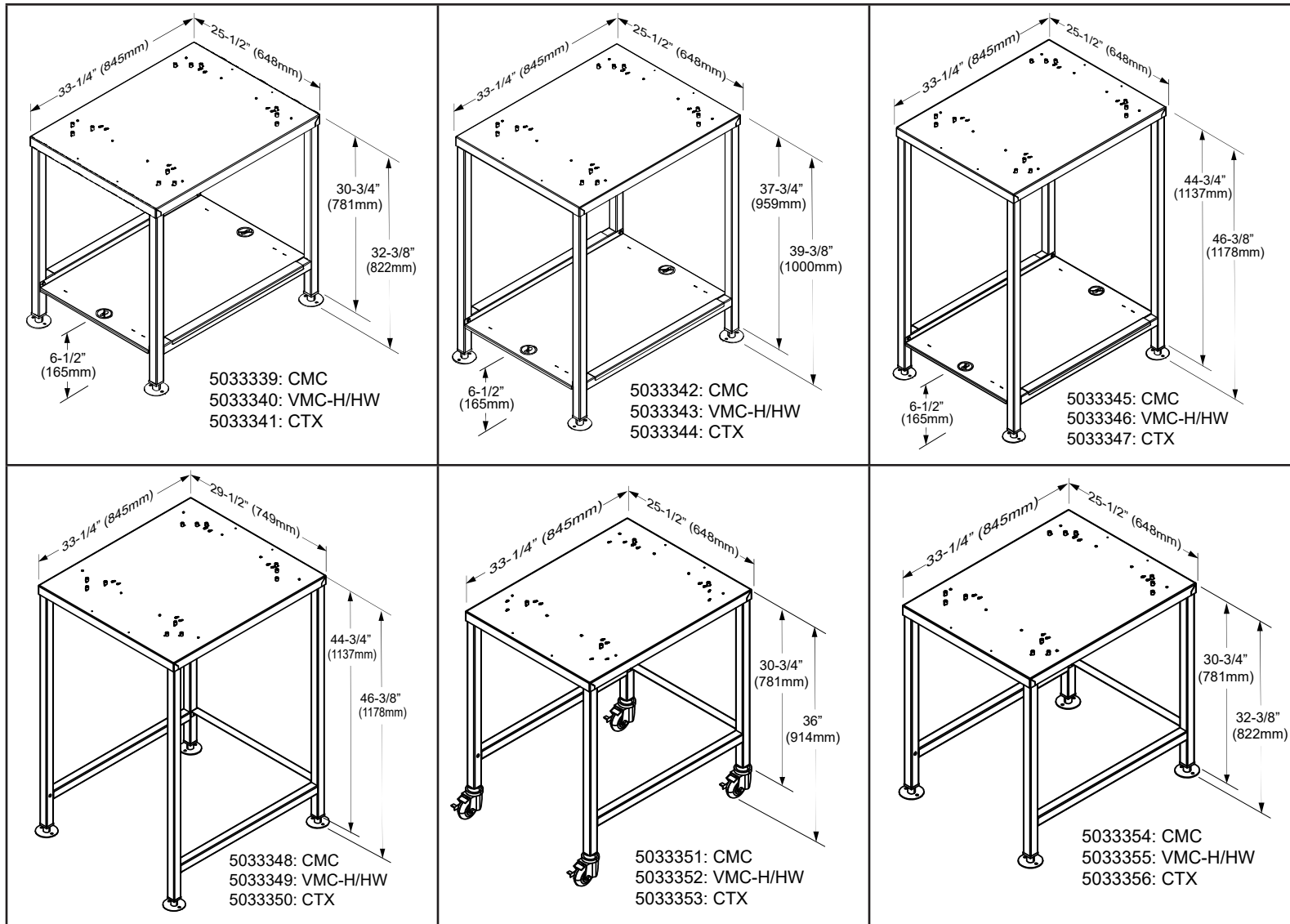

Stand Details [continued]

For stands accomodating various ovens, the first number listed in each cell below is for the Converge [CMC] variation. The second number is for the Vector H/Vector Wide variation, and the third number is for the CTX variation.

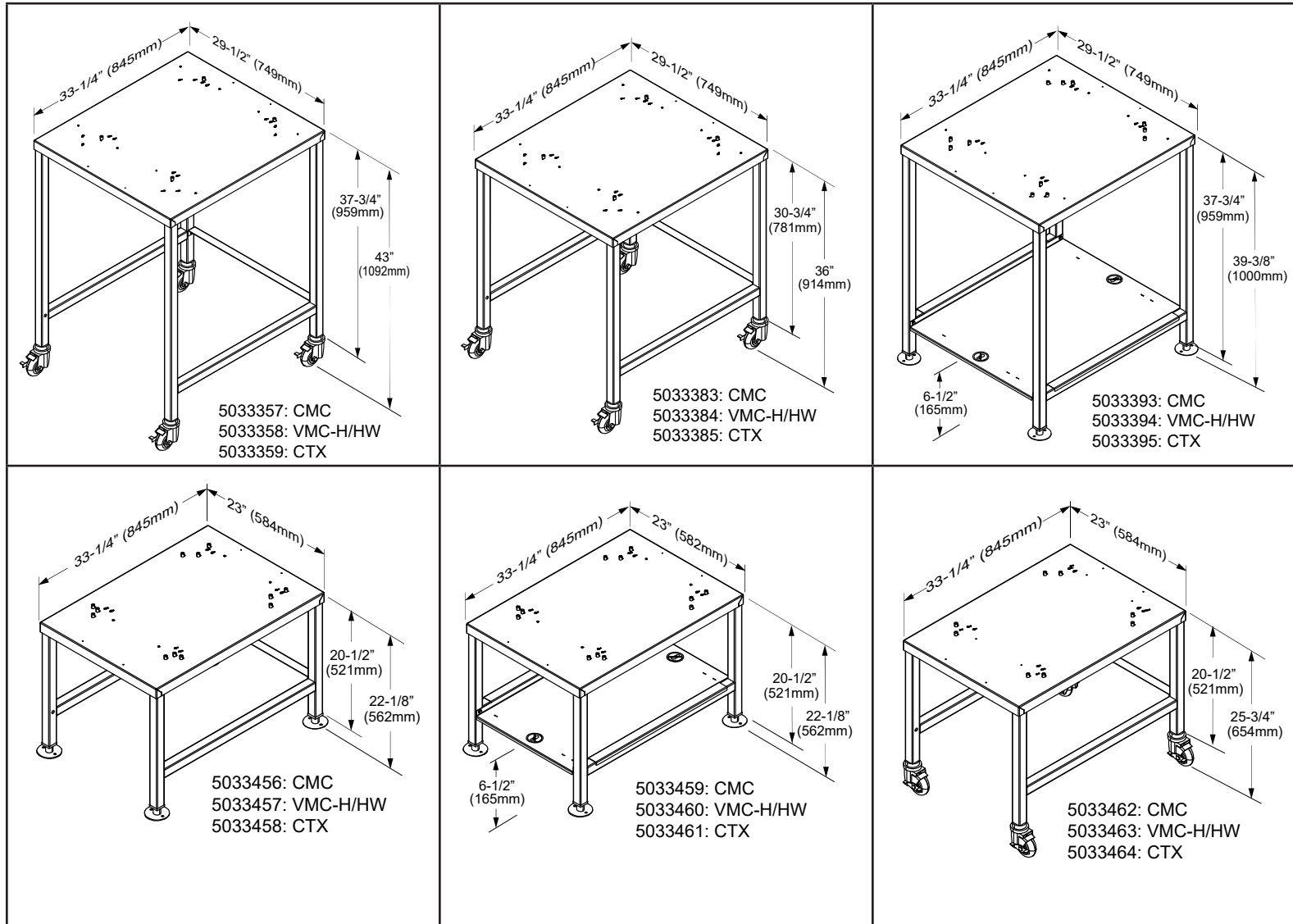

Stand Details [continued]

For stands accomodating various ovens, the first number listed in each cell below is for the Converge [CMC] variation. The second number is for the Vector H/Vector Wide variation, and the third number is for the CTX variation.

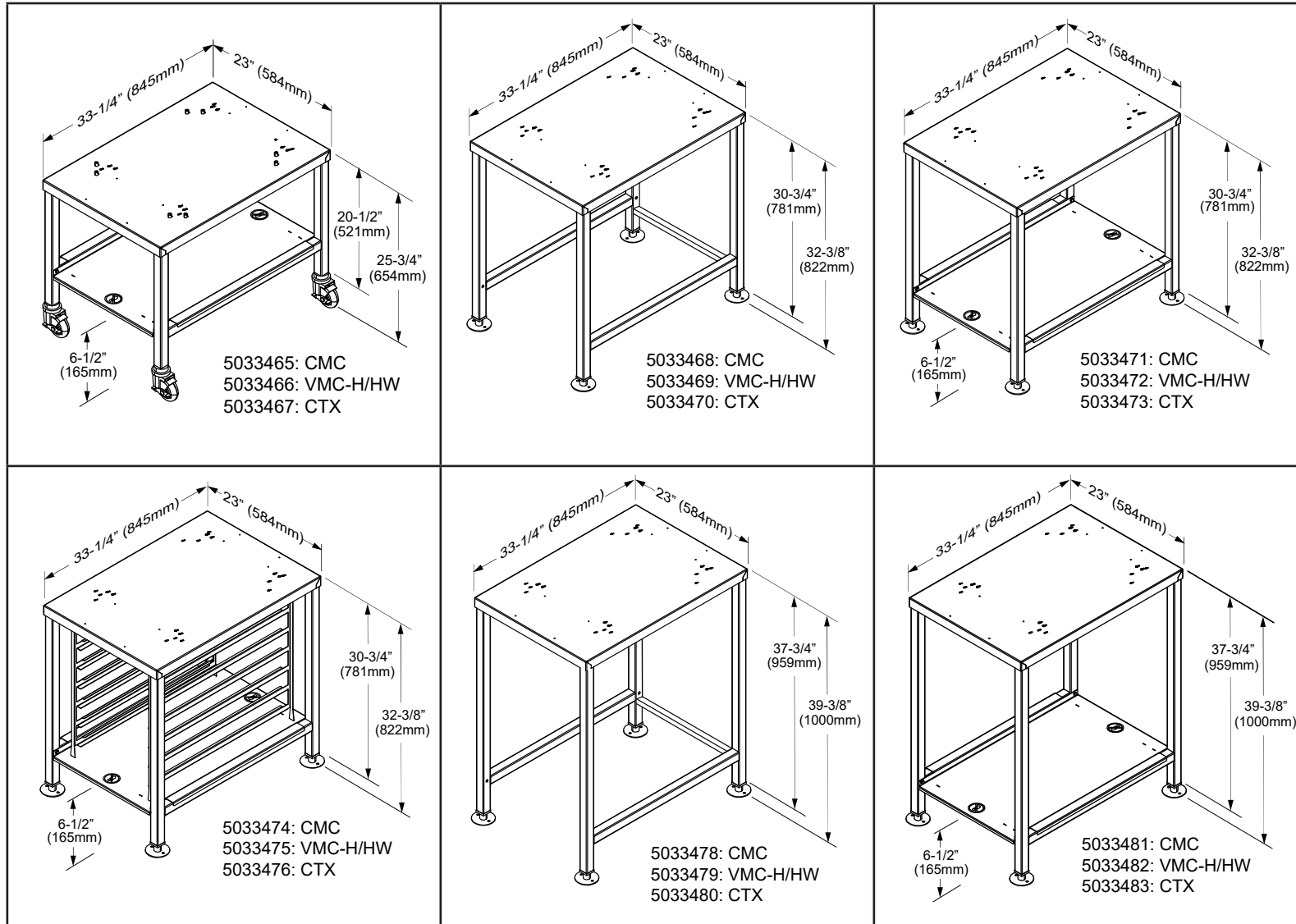

Stand Details [continued]

For stands accomodating various ovens, the first number listed in each cell below is for the Converge [CMC] variation. The second number is for the Vector H/Vector Wide variation, and the third number is for the CTX variation.

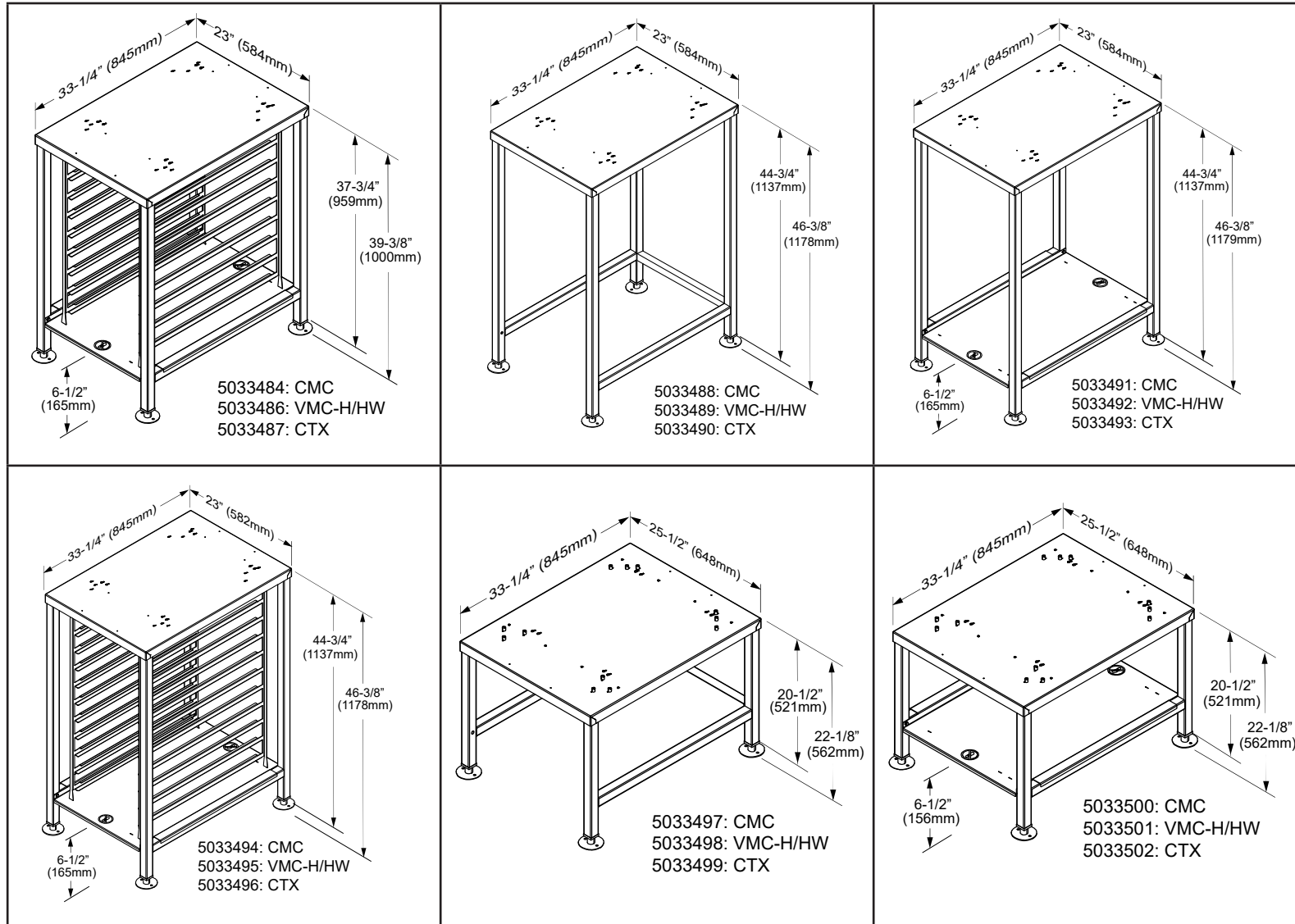

Stand Details [continued]

For stands accommodating various ovens, the first number listed in each cell below is for the Converge [CMC] variation. The second number is for the Vector H/Vector Wide variation, and the third number is for the CTX variation.

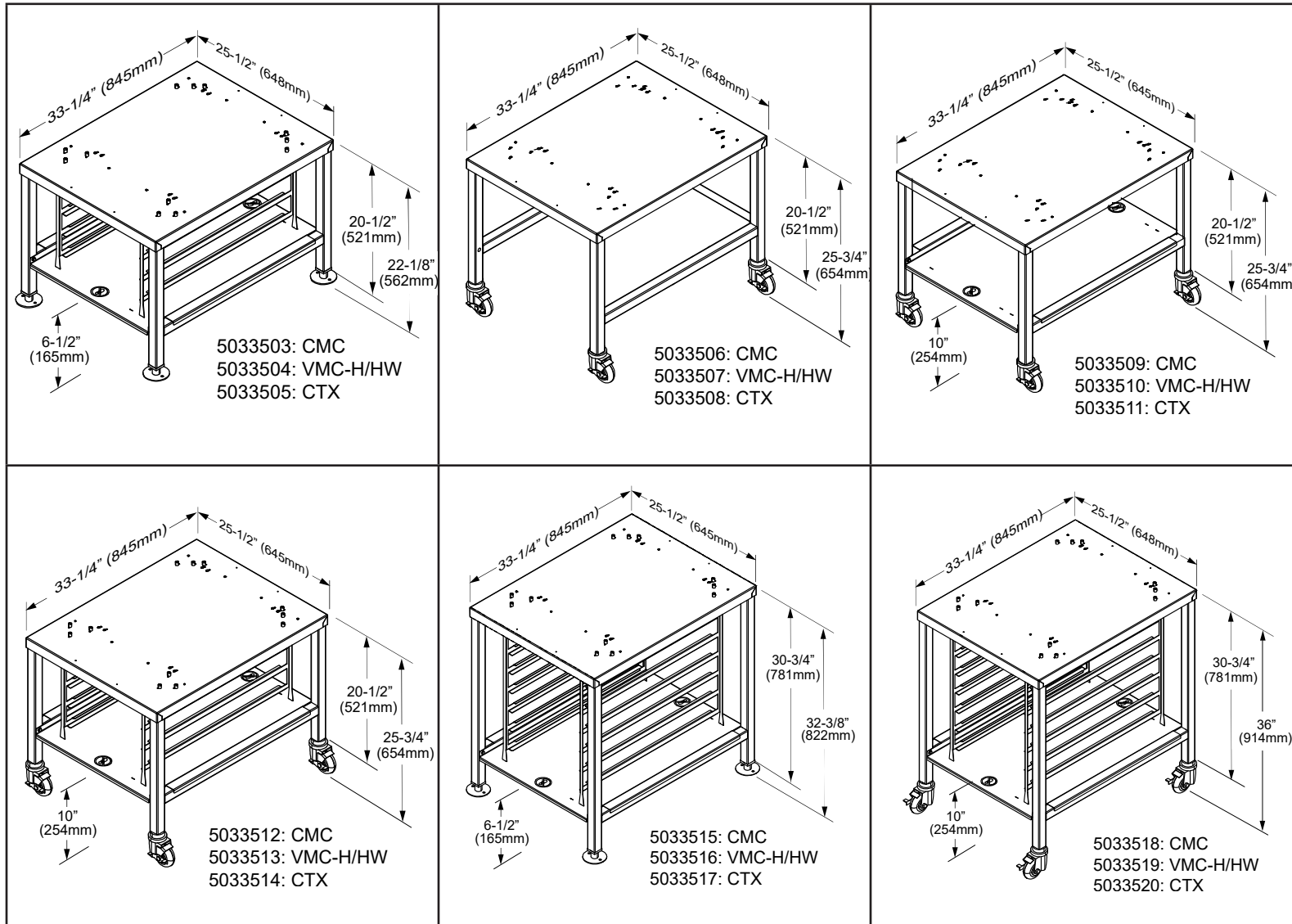

Stand Details [continued]

For stands accommodating various ovens, the first number listed in each cell below is for the Converge [CMC] variation. The second number is for the Vector H/Vector Wide variation, and the third number is for the CTX variation.

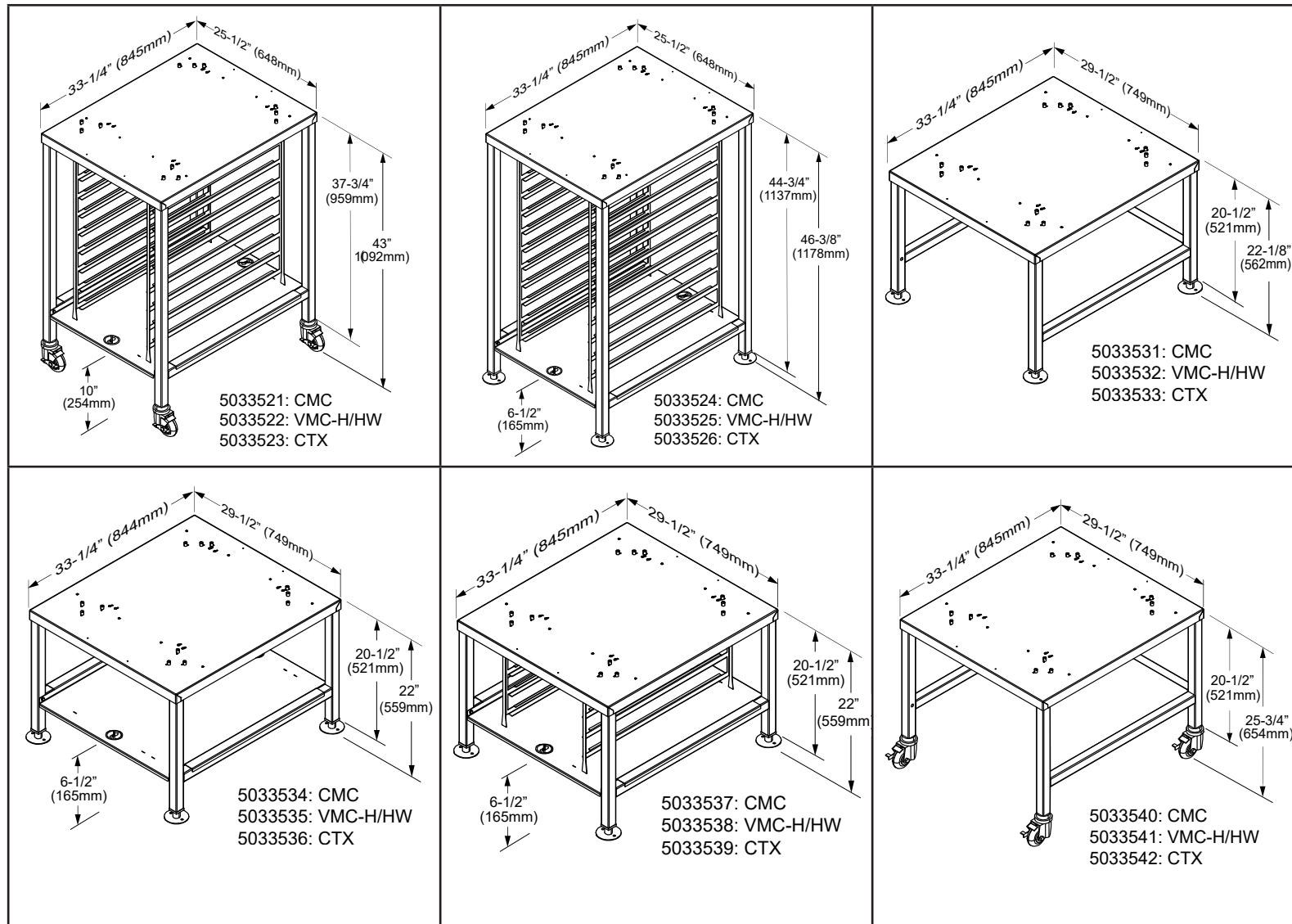

Stand Details [continued]

For stands accommodating various ovens, the first number listed in each cell below is for the Converge [CMC] variation. The second number is for the Vector H/Vector Wide variation, and the third number is for the CTX variation.

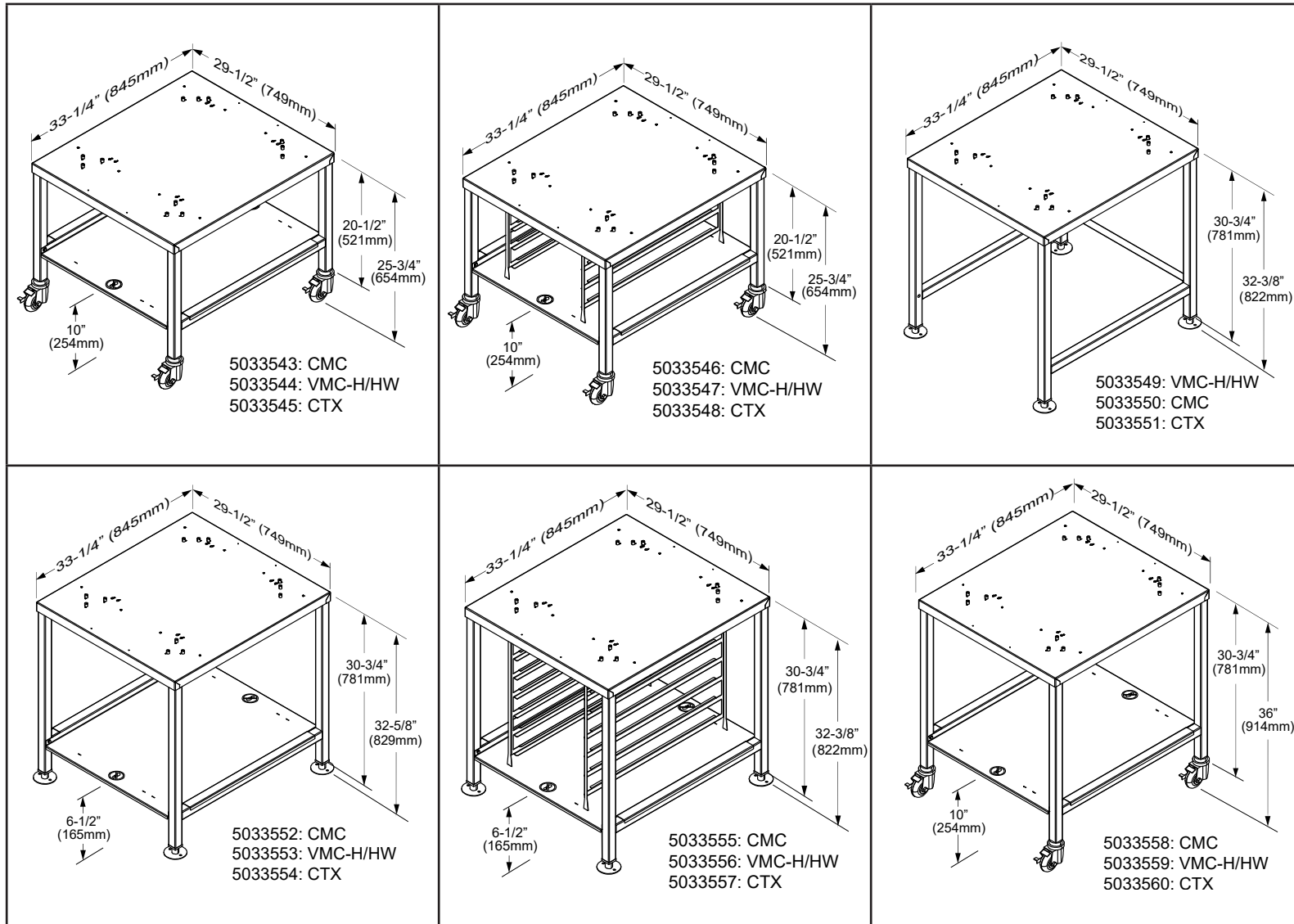

Stand Details [continued]

For stands accomodating various ovens, the first number listed in each cell below is for the Converge (CMC) variation. The second number is for the Vector H/Vector Wide variation, and the third number is for the CTX variation.

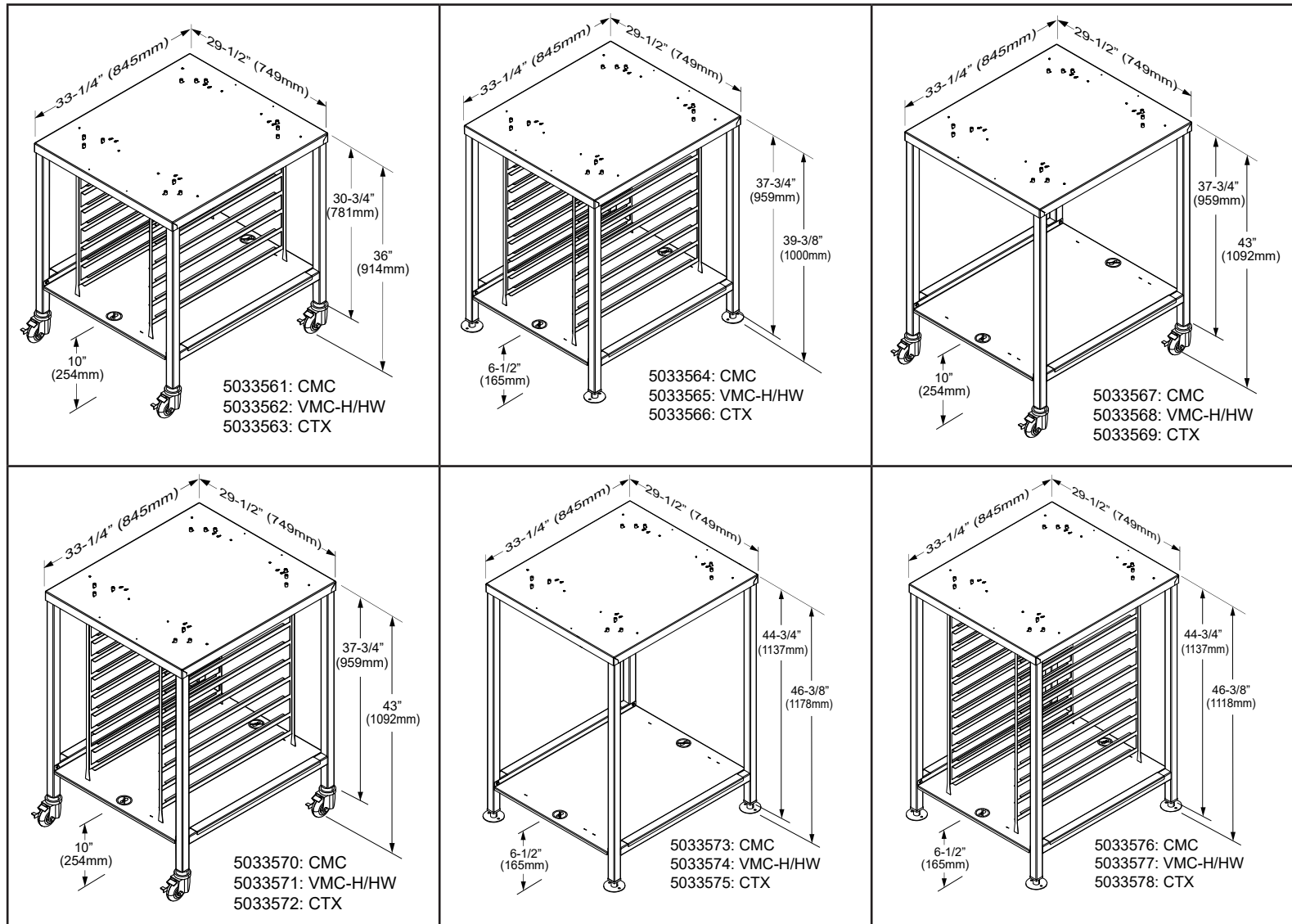

Stand Details [continued]

The stands on this page, and all but the last one on the next page, are designed exclusively for Vector H (VMC-H) ovens. Align the holes on the top panel with existing threaded bolt holes on the underside of the Vector H.

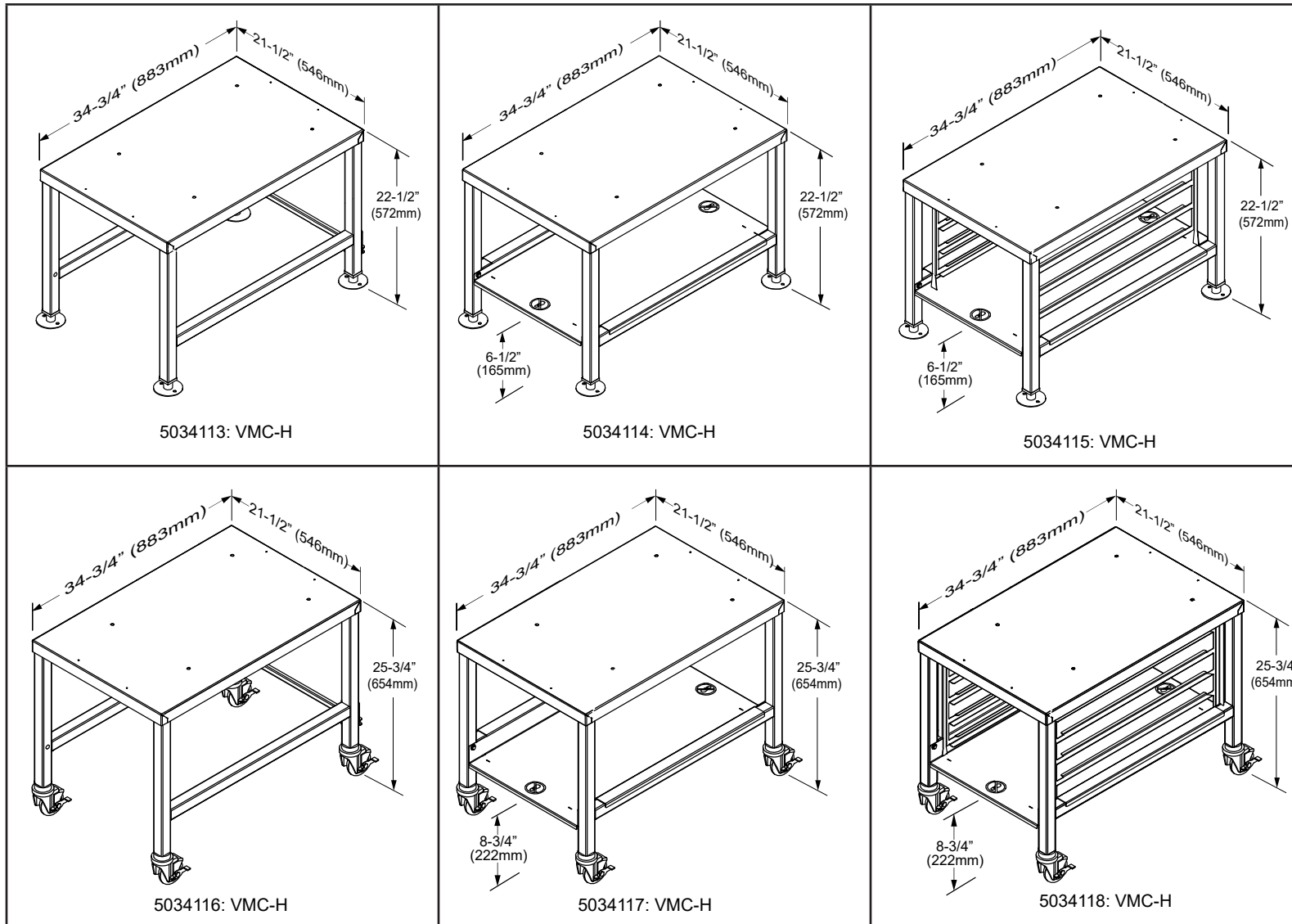

Stand Details [continued]

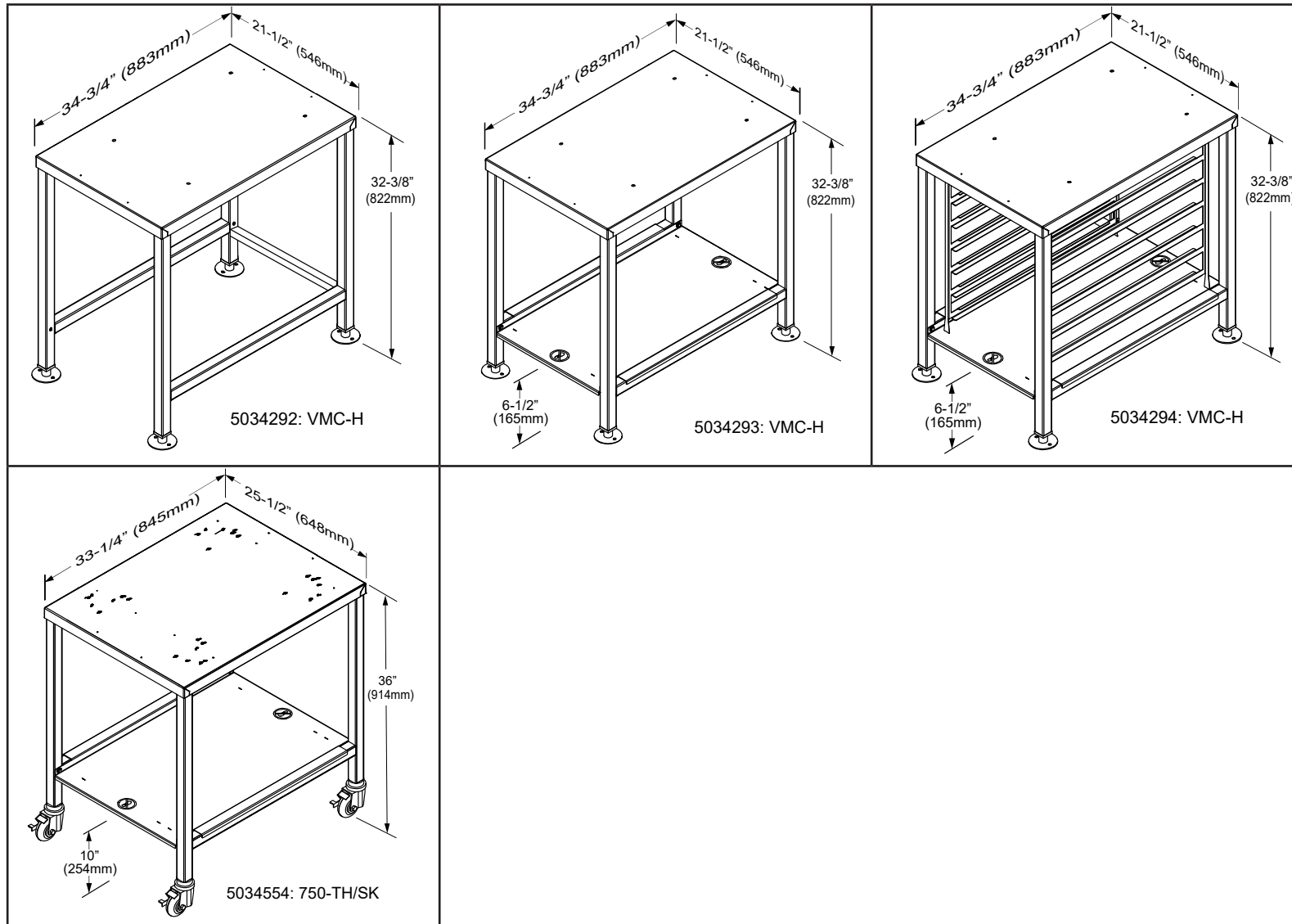



ALTO-SHAAM.

Menomonee Falls, WI U.S.A.

Phone 800-558-8744 | +1-262-251-3800 | alto-shaam.com

ASIA

Shanghai, China
Phone +86-21-6173-0336

AUSTRALIA

Brisbane, Queensland
Phone 800-558-8744

CANADA

Concord, Ontario Canada
Toll Free Phone 866-577-4484
Phone +1-905-660-6781

FRANCE

Aix en Provence, France
Phone +33(0)4-88-78-21-73

GMBH

Bochum, Germany
Phone +49 (0)234 298798-0

ITALY

Padua, Italy
Phone +39 3476073504

INDIA

Pune, India
Phone +91 9657516999

MEXICO

Phone +52 1 477-717-3108

MIDDLE EAST & AFRICA

Dubai, UAE
Phone +971-4-321-9712

CENTRAL & SOUTH AMERICA

Miami, FL USA
Phone +1 954-655-5727

RUSSIA

Moscow, Russia
Phone +7 903 7932331